

SDN Series

The SDN family of DIN Rail power supplies have industry leading performance with a true industrial grade design and high quality that meets difficult industrial environmental conditions including high shock, vibration, and wide temperature ranges over the long life cycle of industrial equipment.

Features

- Industrial grade design.
 - 10°C to 60°C operation without derating. Indefinite short circuit, overvoltage and overtemperature protection.
 - Powers high inrush loads without shutdown or foldback.
 - Rugged metal case and DIN connector.
- Class 2 rated for DeviceNet™ models.
- Narrow width on rail for space critical applications.
- User-friendly front panel.
 - Large, rugged, accessible multiple connection screw terminations.
 - Easy to mount and connect.
- Broad range of product to fit almost any application – 2.5 A-40 A.
- Single and three phase inputs available.
- Highly efficient >90% switching technology.
- High MTBF and reliability
 - High grade and low stress design components.
 - Low inrush current.
 - No fans used or required.
 - Minimal use of electrolytic capacitors.
- New Redundant versions with plug connectors available.
- Three year warranty.



UL 508 Listed
IND. CONT. EQ.
18 WM, EI91000



UL 1950
E137632
CUL/CSA-C22.2
No. 234-M90



EMV and
Low Volt.
Directive

Related Products

- SDP Series
- SFL Series
- SCP Series
- SCL Series

Applications

- Industrial control
- Process control
- Machine control
- DeviceNet™

SDN Specifications (Single Phase)

Description	Catalog Number					
	SDN 8-5-24	SDN 2.5-24-100	SDN 4-24-100	SDN 5-24-100	SDN 10-24-100	SDN 20-24-100 ⁴
Input						
Nominal Voltage	DC 24 V	AC 115/230 V user select				115/230 V auto select
-Range	18-32 VDC	85-132/176-264 VAC				
-Frequency	N/A	47 - 63 Hz				
Nominal Current ¹	1.5 A. / 2.9 A	1.3 A. / 0.7 A	2.6 A. / 1.4 A		6 A / 2.8 A typical	12 A/6 A
-Inrush current max.	typ. < 5.1 A	typ. < 25 A	typ. < 15 A		typ. < 30 A	typ. < 85 A
Efficiency (Losses ²)	80% typ (8 W)	> 87.5% typ (8.6 W)	> 90% typ (13 W)		> 90% typ (26.7 W)	> 90% typ (48 W)
Output						
Nominal Voltage	5 VDC	24 VDC			24 - 28 VDC Adj.	
-Tolerance	< 1% overall	<±2% overall			<±2% overall	
-Ripple ³	< 50 mVpp	< 25 mVpp			< 30 mVpp	< 20 mVpp
Nominal Current	8 A (40 W)	2.5 A (60 W)	4 A (100 W) Class 2	5 A (120 W)	10 A (240 W) 10 A 60 °C 12 amps at 45 °C	20 A (480 W)
-Peak Power ⁵	N/A	2x Nominal Current < 2 sec.	4.2 A max	6 A (1 minute @ 45°C) 2x Nominal Current < 2 sec.	12 A 2x Nominal Current < 2 sec.	25 A (1 minute @ 45°C) 2x Nominal Current < 2 sec.
-Current Limit	Foldback	Fold Forward	4.2 A max Class 2	Fold Forward		Fold Forward until Hiccup off at <14 V, auto-reset. (Switch for Constant Current)
Holdup Time	> 10 ms	> 20 ms				>16 ms
Parallel Operation	SDN 2.5; SDN 5 and SDN 10 may be paralleled by brute force – see the RED options on the preceeding pages. The SDN20 and 30 may be paralleled by selecting the "P" position of the switch on the bottom of the unit.					
EMC	EN50081-1,-2 Class B EN55011, EN55022 Radiated and Conducted					
-Emissions	EN50082-1, -2; EN61000-4-2 Level 4, EN61000-4-3 Level 3; EN61000-4-6 Level 3; EN61000-4-4; EN61000-4-5 Isolation Class 3, EN61000-4-11; VDE 0160/W2.					
-Immunity	EN60950; EN60204; UL508 Listed, cULus; UL1950, cRUus, SDN4 & 2.5 - Class 2 LPS; CE (LVD 73/23 & 93/68/EWG, EMC 89/336 & 93/68/EWG; Transient Handling VDE 0160/W2. SDN 8-5-24 complies to all of the above; Approvals pending (SELV < 42 V).					
Approvals	EN60950; EN60204; UL508 Listed, cULus; UL1950, cRUus, SDN4 & 2.5 - Class 2 LPS; CE (LVD 73/23 & 93/68/EWG, EMC 89/336 & 93/68/EWG; Transient Handling VDE 0160/W2. SDN 8-5-24 complies to all of the above; Approvals pending (SELV < 42 V).					
General Protection/Safety	Protected against short-circuit, overload, open-circuit. Overvoltage protection (OVP) for output set @32 V ±10%. Protection class I (IEC536), degree of protection: IP20 (VDE 0470, IEC 529) Safe low voltage: SELV (acc. EN60950).					
Status Indicators	Green LED on when Vout = "OK". See SDN-RED series for DC or Relay Contact.					
Installation						
-Fusing	Internally fused, however external 10 A slow acting fusing for the input is recommended (SDN 20 requires a 20A, B-type circuit breaker). Outputs are capable of providing high currents for short periods of time for inductive load startup or switching. Fusing may be required for wire/loads if 2x Nominal O/P current rating cannot be tolerated. Continuous current overload allows for reliable fuse tripping.					
-Mounting	Simple snap-on system for DIN Rail TS35/7.5 or TS35/15 or chassis-mounted (optional screw mounting set SDN-PMBRK required).					
-Connections	Input: screw terminals, connector size range: 1.5...6 mm (solid) respectively. 0.5...4 mm (flexible) Output: two connectors per output, current handling capacity 30 A each.					
-Case	Fully enclosed metal housing with fine ventilation grid to keep out small parts.					
-Free Space	25 mm above and below -10 mm in front		25 mm above and below -15 mm in front			70 mm above and below -25 mm left and right -15 mm in front
H x W x D (inches/mm)	4.88 x 1.97 x 4.04 (124 x 50 x 103)		4.88 x 2.56 x 4.04 (124 x 65 x 103)		4.88 x 5.39 x 4.04 (124 x 137 x 103)	4.88 x 8.94 x 4.04 (124 x 227 x 103)
Weight (lbs/g)	1lb (460g)		1.5lbs (620g)		2.2lbs (1100g)	3lbs (1520g)
Temperature	Storage: -25 °C...+85°C operation. 10°-70°C; 0°-60°C full power with operation to 70°C possible with a linear derating to half power from 60°C to 70°C.					
Warranty	3 years					

¹ Input current ratings are conservatively specified with low input, line conditions, worst case efficiency values and power factor spikes. Input current at nominal input line settings will be typically half these values.

² Losses are heat dissipation in watts at full load, nominal input line.

³ Ripple/noise is stated as typical values when measured with a 20 MHz, bandwidth scope and 50 Ohm resistor.

⁴ SDN20-24-100 can replace the SDN20-24-200. The units is the same size as the -200 with an autoselectable 115/230 VAC (no switch required. -200 units are 208/230 only).

⁵ All peak power is calculated at 24 Volt levels.

SDN Specifications (Three Phase)

Description	Catalog Number				
	SDN 5-24-480	SDN 20-24-400	SDN 20-24-480	SDN 30-24-480	SDN 40-24-480
Input					
Nominal Voltage	3PH AC380-480 VAC, Auto Range	3PH AC380 V	3PH AC480 V	3PH AC380-480 VAC, Auto Range	
-Range	340-576 VAC	340-479 VAC	408-576 VAC	340-576 VAC	
-Frequency	47 - 63 Hz				
Nominal Current¹	3.0 A. / 0.5 A	3 x 1.5 A		3 x 2.0 A	3 x 3.0 A
-Inrush current	< 22 A	< 15 A		< 17 A (@576)	< 30 A
Efficiency (Losses²)	> 90% typ (12 W)	> 90% typ (48 W)		> 90% typ (72 W)	> 90% typ (96 W)
Output					
Nominal Voltage	24 - 28 VDC Adj.				
-Tolerance	< ±2% overall				
-Ripple ³	< 20 mVpp				< 50 mVpp
Nominal Current	5 A	20 A		30 A	40 A
-Peak Power (calculated at 24 Volt levels)	6 A	25 A		30 A	45 A
-Current Limit	Constant Current 2x Nominal for 2 sec.	Constant Current until Hiccup off at $V_{out} < 14 V$, 2x Nominal for 2 sec.		Constant Current until Hiccup off at $V_{out} < 10 V$, 2x Nominal for 2 sec.	Constant Current 2x Nominal for 2 sec.
Holdup Time	> 10 ms	> 11 ms			> 11 ms
Parallel Operation	The SDN20/30 may be passively paralleled by selecting the "P" position of the switch on the bottom of the unit. The SDN40 contains active current balancing. (For Critical Redundant applications, see External Redundant Option Module (SDN-RED) that includes external diodes and monitoring circuitry).				
EMC	EN50081-1, EN50082-2 Class B EN55011, EN55022 Radiated and Conducted				
-Emissions	EN50082-1, -2; EN61000-4-2 Level 4, EN61000-4-3 Level 3; EN61000-4-6 Level 3; EN61000-4-4; EN61000-4-5 Isolation Class 3, EN61000-4-11; VDE 0160/W2.				
-Immunity					
Approvals	EN60950; EN60204; UL508 Listed, cULus; UL1950, cRUus, SDN4 & 2.5 - Class 2 LPS; CE (LVD 73/23 & 93/68/EWG, EMC 89/336 & 93/68/EWG; Transient Handling VDE 0160/W2.				
General Protection/Safety	Protected against short-circuit, overload, open-circuit. Overvoltage protection (OVP) for output set @32 V ±10%. Protection class I (IEC536), degree of protection: IP20 (VDE 0470, IEC 529) Safe low voltage: SELV (acc. EN60950). Three phase units have phase loss protection where unit will shutdown when one or two phases are lost. The supplies will operate with one phase lost if loading is 70% of nominal power.				
Status Indicators	DC Ok LED: Green LED on, when V_{out} "OK" or $V_{out} > V_{out}$ set nominal - 2 Volts; Overload LED: Indicator LED for Overload is red for overload conditions [14 V (10 V < V_{out} < V_{out} set nominal - 2 Volts); and flashing red for short circuit conditions ($V_{out} < 14V$ (10V); SDN20 (14 V) and SDN30 (10V); SDN40 has DC OK and Red for Overload; where $V_{out} = < V_{out}$ nominal - 2 Volts.				
Signaling	SDN40 only; (High = 24 V, Low = Signal Ground). Temp Warning Signal: High/Good; Power good High/Good; Remote on/off, Off = Low. Current Sense (I_{out} measure, 1 V per 10 A with measure resistor > 100 k Ohm resp. 10 mA per 10A I_{out} with meas. Resistor < 100 Ohm. See external SDN-RED module for DC OK and Isolation Diode protection on SDN20, 30 and 40.				
Installation					
Fusing	External 10 A slow acting circuit protection for the input is recommended. Outputs are capable of providing high currents for short periods of time. Fusing may be required for wire/loads if 2x Nominal O/P current rating cannot be tolerated.				
Mounting	Simple snap-on system for DIN Rail TS35/7.5 or TS35/15 or chassis-mounted (optional screw mounting set SDN-PMBRK required).				
Connections	Input: screw terminals, connector size range: 1.5...6 mm (solid) respectively. 0.5...4 mm (flexible) Output: two connectors per output, current handling capacity 30 A each (40 A on the SDN40).				
Case	Fully enclosed metal housing with fine ventilation grid to keep out small parts (e.g., screws).				
Free Space	25 mm above and below -15 mm in front		70 mm above and below 25 mm left and right -15 mm in front		
H x W x D (inches/mm)	4.88 x 2.91 x 4.04 (124 x 74 x 103)	4.88 x 8.94 x 4.04 (124 x 227 x 103)		4.88 x 9.72 x 4.45 (125 x 247 x 113)	4.92 x 11.10 x 4.45 (125 x 282 x 118)
Weight (lbs/g)	1.7 lb (730g)	3 lbs (1520g)		4 lbs (2000g)	6.6 lbs (3300g)
Temperature	Storage: -25°C...+85 °C Operation: -10°-60°C full power with operation to 70°C possible with a linear derating to half power from 60°C to 70°C.				
Warranty	3 years				

¹ Input current ratings are conservatively specified with low input, line conditions, worst case efficiency values and power factor spikes. Input current at nominal input line settings will be typically half these values.

² Losses are heat dissipation in watts at full load, nominal input line.

³ Ripple/noise is stated as typical values when measured with a 20 MHz, bandwidth scope and 50 Ohm resistor.

SDN Series Dimensions

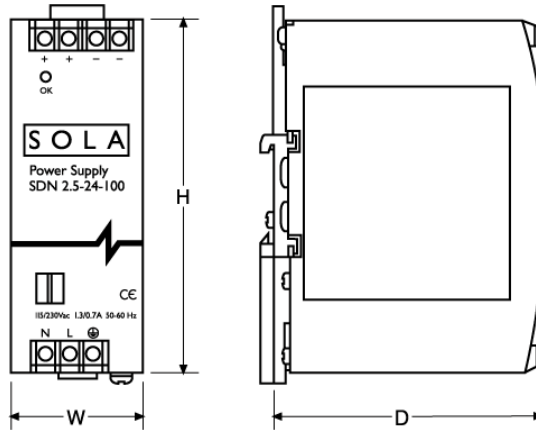

Catalog Number	Dimensions - inches (mm)		
	H	W	D
SDN 2.5-24-100 (RED)	4.88 (124)	1.97 (50)	4.04 (103)
SDN 4-24-100	4.88 (124)	2.91 (74)	4.04 (103)
SDN 5-24-100 (RED)	4.88 (124)	2.91 (74)	4.04 (103)
SDN 8-5-24	4.88 (124)	1.97 (50)	4.04 (103)
SDN 5-24-480	4.88 (124)	2.91 (74)	4.04 (103)

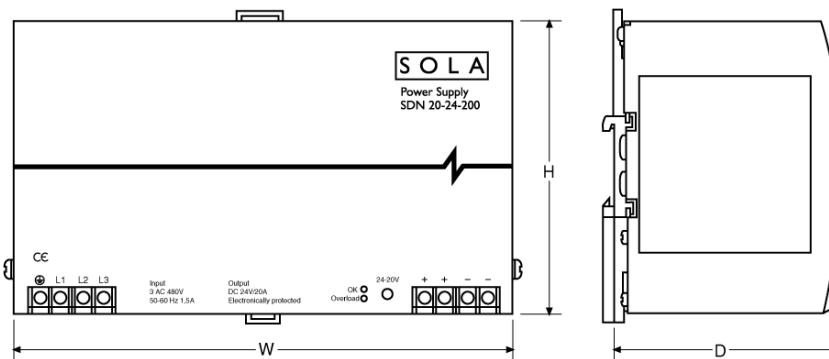

Catalog Number	Dimensions - inches (mm)		
	H	W	D
SDN 10-24-100 (RED)	4.88 (124)	5.39 (137)	4.04 (103)
SDN 20-24-100; -200, -480	4.88 (124)	8.94 (227)	4.04 (103)
SDN 30-24-480	4.88 (124)	9.72 (247)	4.45 (113)
SDN 40-24-480	4.92 (125)	11.10 (282)	4.45 (113)

SDN Series Mounting

DIN Rail Mounting

Snap on the DIN Rail:

1. Tilt unit slightly backwards
2. Put it onto the DIN Rail
3. Push downwards until stopped
4. Push at the lower front edge to lock
5. Shake the unit slightly to ensure that the retainer has locked

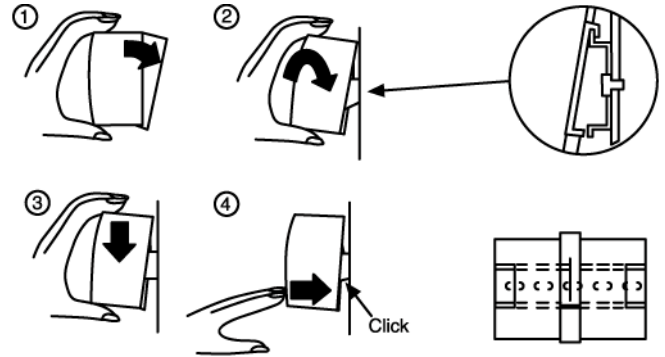

Alternative Screwing-on: Using the optional SDN-PMBRK accessory, the unit can also be screwed onto plane surfaces (without DIN Rail).

Detachment from DIN Rail:

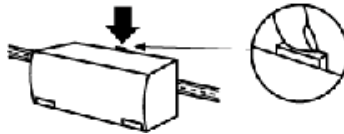

Press button downwards (to unlock) and remove the unit from the DIN Rail.

Chassis Mounting

Instead of snapping a Sola SDN unit on the DIN Rail, you can also screw it on by means of the screw mounting set SDN-PMBRK.

This set consists of two aluminum profiles, which replace the existing two profiles at the back of the unit.

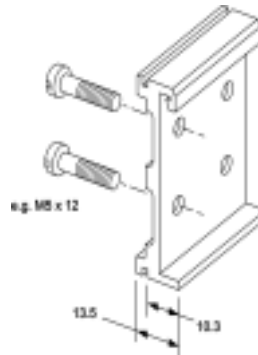

Dimensions

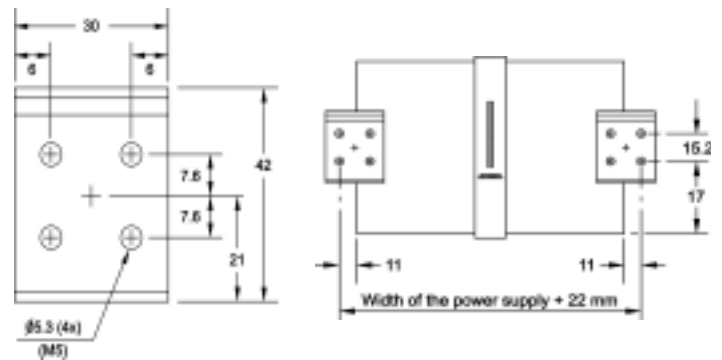

Note:

You need one SDN-PMBRK per unit.

- In addition, two screws are required per SDN-PMBRK (e.g. M5 x 12), which are not included with the set.

Exchanging the Profiles

a. At the unit:

1. Remove the screw from the profile.
2. Pull the profile outwards to remove.

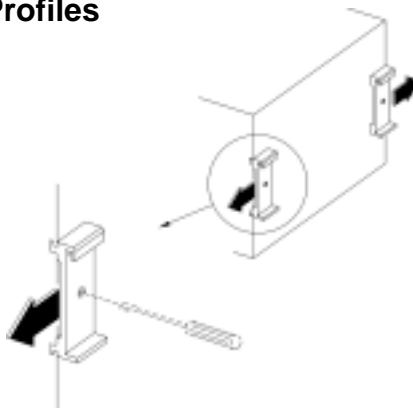

- b. Push the SDN-PMBRK profile into the groove as far as possible. Secure with screw.

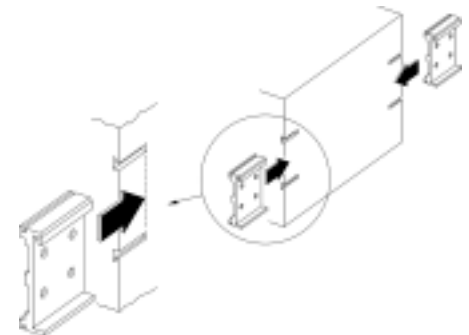

Note the orientation:

The profile fits into the groove only as shown here.