

NOTES: UNLESS OTHERWISE NOTED

1. MACHINED SURFACE ROUGHNESS 64
O-RING GROOVES AND SURFACES 32
2. REMOVE ALL BURRS/SHARP CORNERS

CUT INTO 2 PARTS
AS FINAL OPERATION

BILL OF MATERIAL

NO.	REQ'D	REF DRW	DESCRIPTION	MATERIAL
N/A	1	SD2-012A	STAGE 1 CLAMP	COPPER OFHC

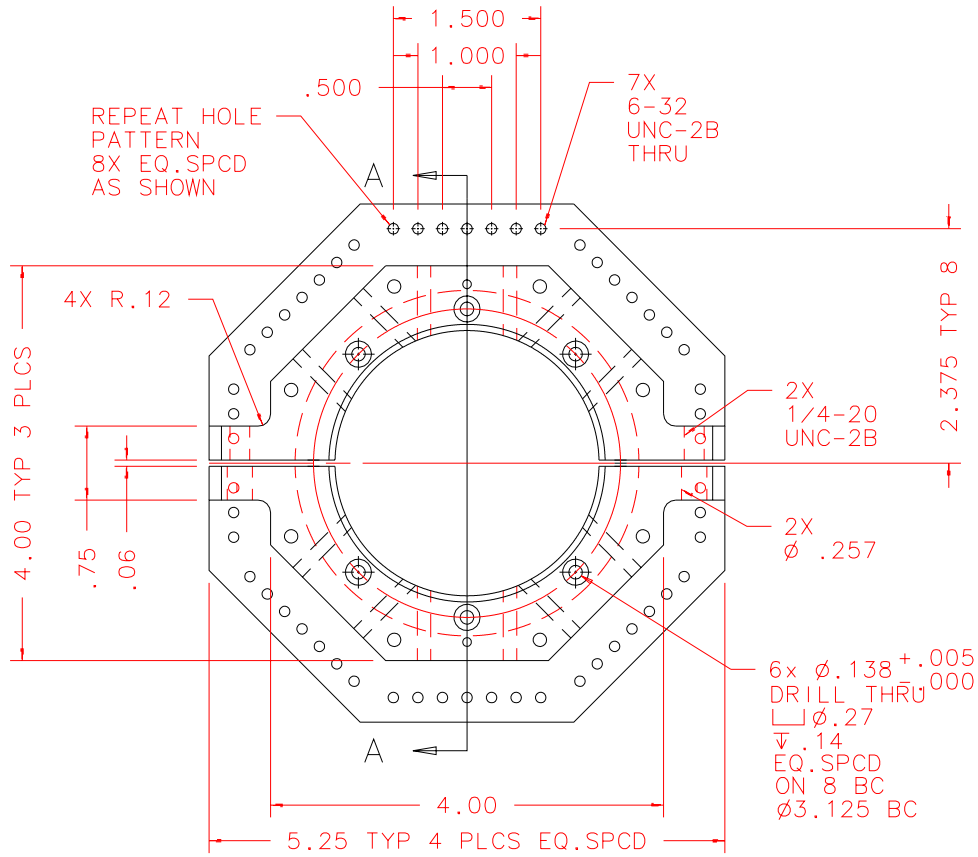

FRONT: SCALE 1:2

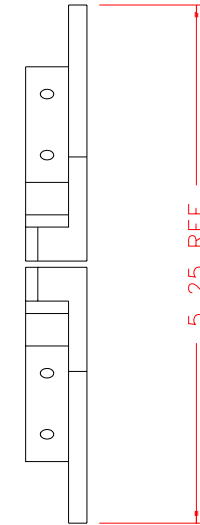

RIGHT: SCALE 1:2

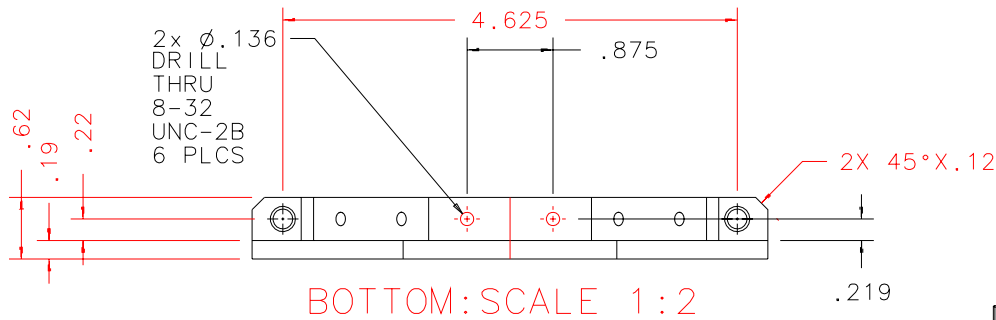

REVDATE: 01/13/99	REVISION: ADD THREADED UTILITY HOLES
REVDATE: 10/07/98	REVISION: ADD SHEET 3
REVDATE: N/A	REVISION: N/A
DATE: 04/11/97	INSTITUTE FOR ASTRONOMY
DESIGN: STAHLBERGER	2680 WOODLAWN DR. HONOLULU, HI 96822
DRAWN: STAHLBERGER	INSTRUMENT: SPEX - CROSS DISPERSED SPECTROGRAPH
APPR'D: J. RAYNER	PART NAME: STAGE 1 CLAMP
TOLERANCES	
X.X	+/- .015
X.XX	+/- .005
X.XXX	+/- .002
ANGLE	+/- 30 min
FRACTION	+/- 1/32
TELESCOPE: IRTF	
DRW NO: SD2-012A	SCALE: NOTED
SIZE: A	JOS NO: 725
SHEET: 1 OF 3	

PLOT: 10/19/99

SD2-001A
NEXT ASSY