

NOTES: UNLESS OTHERWISE NOTED
 1. MACHINED SURFACE ROUGHNESS 64
 O-RING GROOVES AND SURFACES 32
 2. REMOVE ALL BURRS/SHARP CORNERS

BILL OF MATERIAL				
NO.	REQ'D	REF DRW	DESCRIPTION	MATERIAL
N/A	1	SMO-024B	SOCKET COVER CUSTOM	ALU 6061-T6

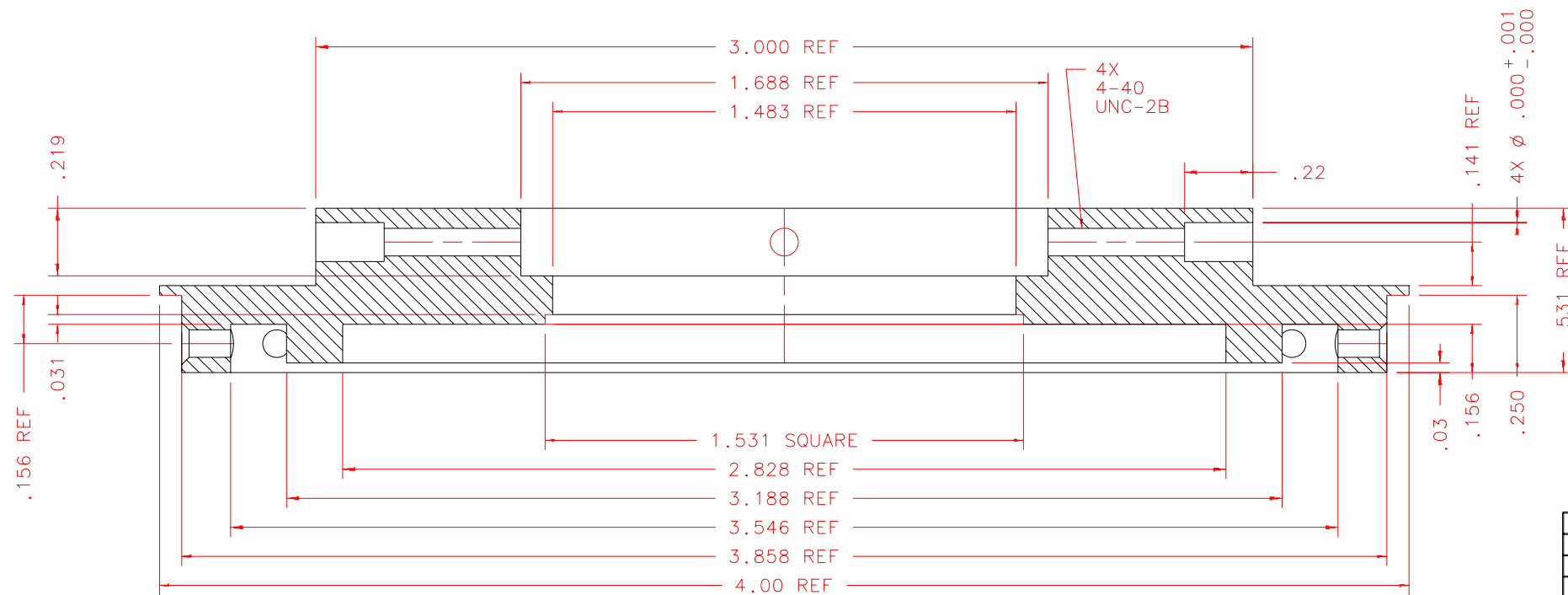
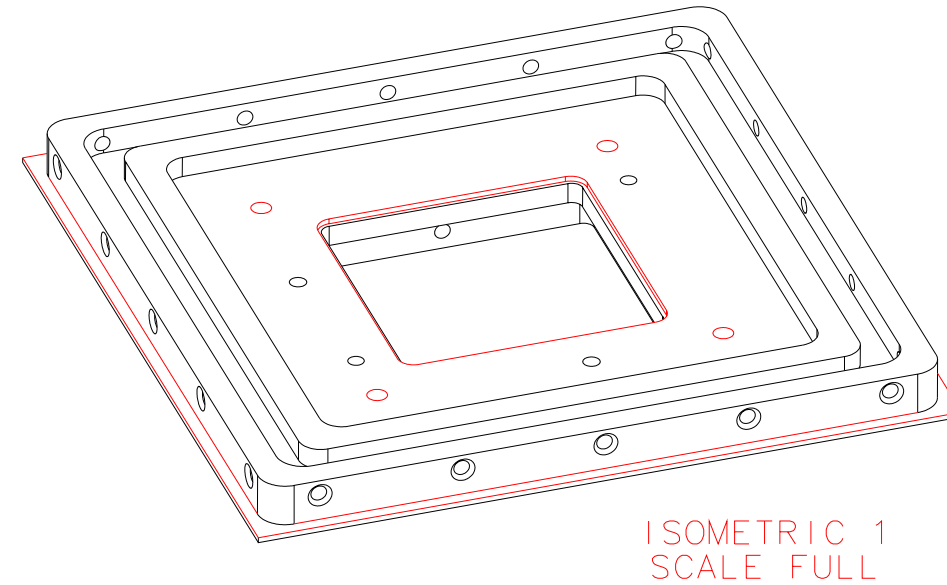
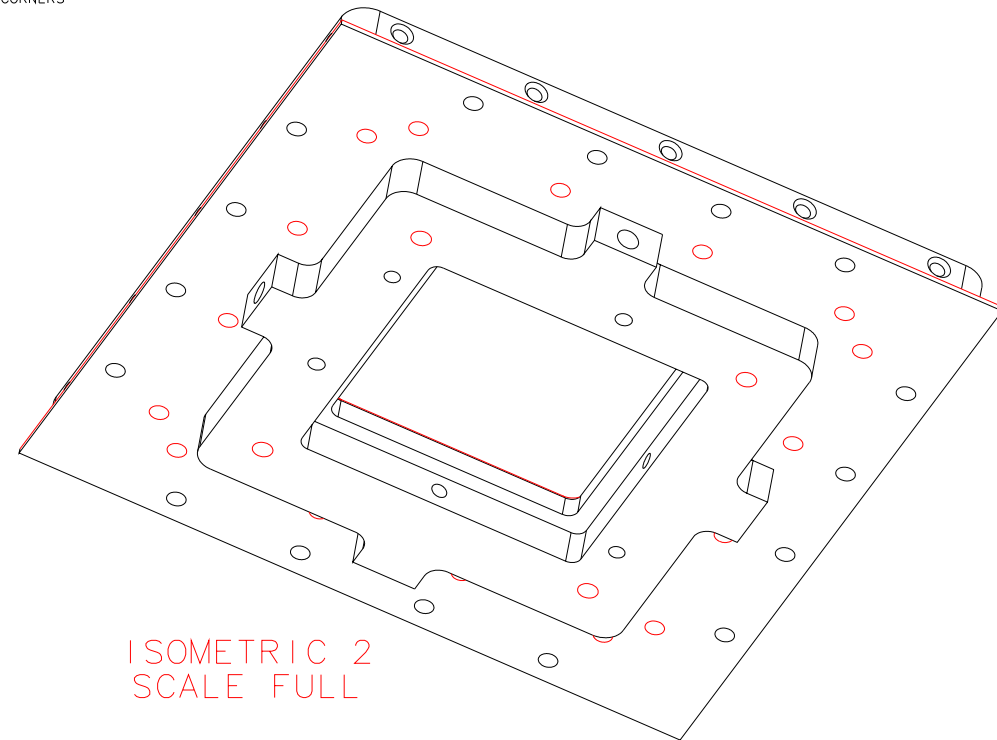

SECTION A-A
 SCALE 2:1

REVDATE: N/A	REVISION: N/A
DATE: 11/06/97	INSTITUTE FOR ASTRONOMY
DESIGN: STAHLBERGER	2680 WOODLAWN DR. HONOLULU, HI 96822
DRAWN: STAHLBERGER	INSTRUMENT: SPEX - CROSS DISPERSED SPECTROGRAPH
APPR'D: J. RAYNER	PART NAME: SOCKET COVER CUSTOM
TOLERANCES	TELESCOPE: IRTF
X.X +/- .015	DRW NO: SMO-024B
X.XX +/- .005	SCALE: 1:2
X.XXX +/- .002	SIZE: B
ANGLE +/- 30 min	JOS NO: 725
FRACTION +/- 1/32	SHEET: 3 OF 3