

NOTES: UNLESS OTHERWISE NOTED

1. MACHINED SURFACE ROUGHNESS 64
O-RING GROOVES AND SURFACES 32
2. REMOVE ALL BURRS/SHARP CORNERS

BILL OF MATERIAL				
NO.	REQ'D	REF DRW	DESCRIPTION	MATERIAL
N/A	4	SF6-015A	DICHROIC MOUNT BACK BAFFLE	ALU 6061-T6

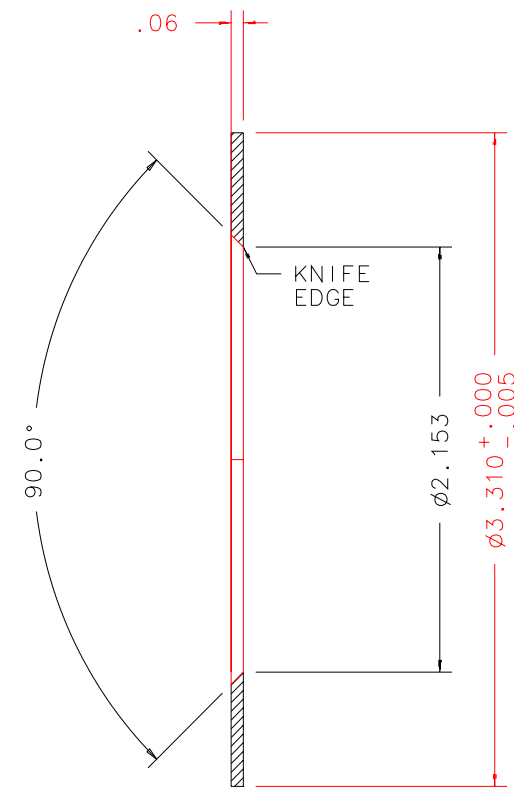
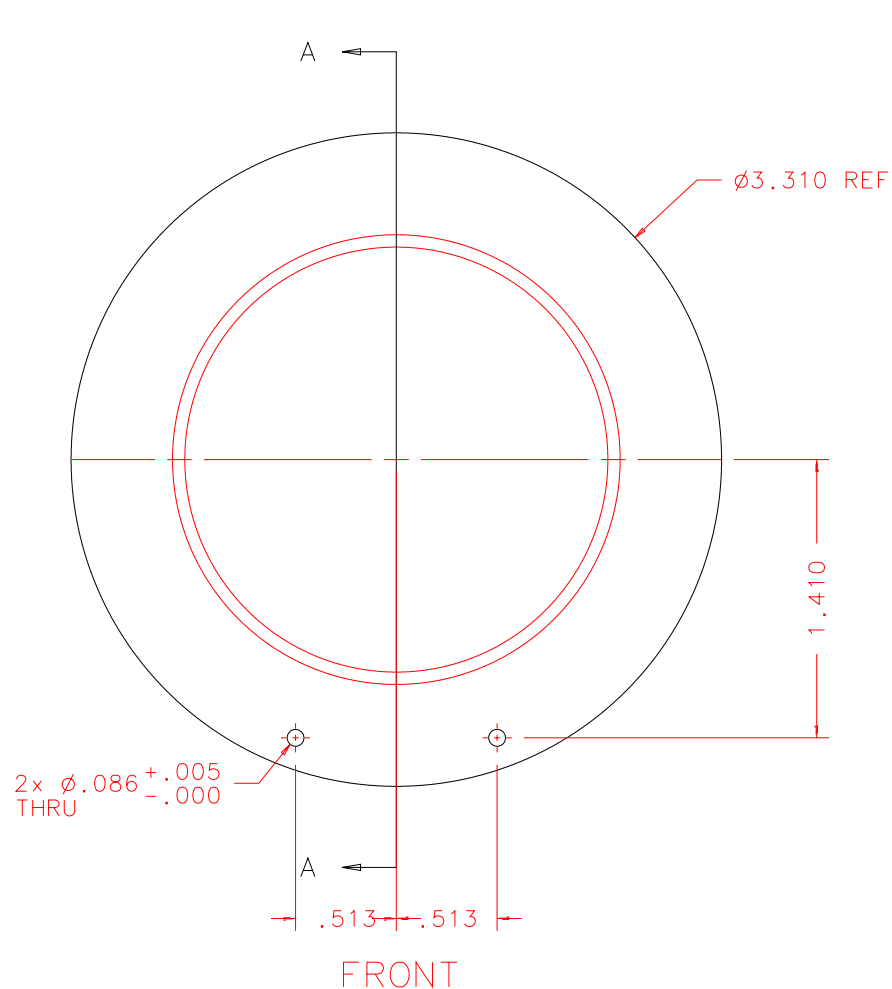

PLOT: 10/19/99

SF6-001A
NEXT ASSY

REVDATE: 08/30/99	REVISION: SQUARE BAFFLE CHANGD TO ROUND
REVDATE: N/A	REVISION: N/A
DATE: 02/17/99	INSTITUTE FOR ASTRONOMY
DESIGN: STAHLBERGER	2680 WOODLAWN DR. HONOLULU, HI 96822
DRAWN: STAHLBERGER	INSTRUMENT: SPEX - CROSS DISPERSED SPECTROGRAPH
APPR'D: J. RAYNER	PART NAME: DICHROIC MOUNT BACK BAFFLE
TOLERANCES	
X.X	+/- .015
X.XX	+/- .005
X.XXX	+/- .002
ANGLE	+/- 30 min
FRACTION	+/- 1/32
DRW NO: SF6-015A	SCALE: 1:1
SIZE: A	JOS NO: 725
SHEET: 1 OF 1	