

NOTES: UNLESS OTHERWISE NOTED

1. MACHINED SURFACE ROUGHNESS 64
O-RING GROOVES AND SURFACES 32
2. REMOVE ALL BURRS/SHARP CORNERS

BILL OF MATERIAL				
NO.	REQ'D	REF DRW	DESCRIPTION	MATERIAL
N/A	1	SF8-011A	ACCESS COVER	ALU 6061-T6

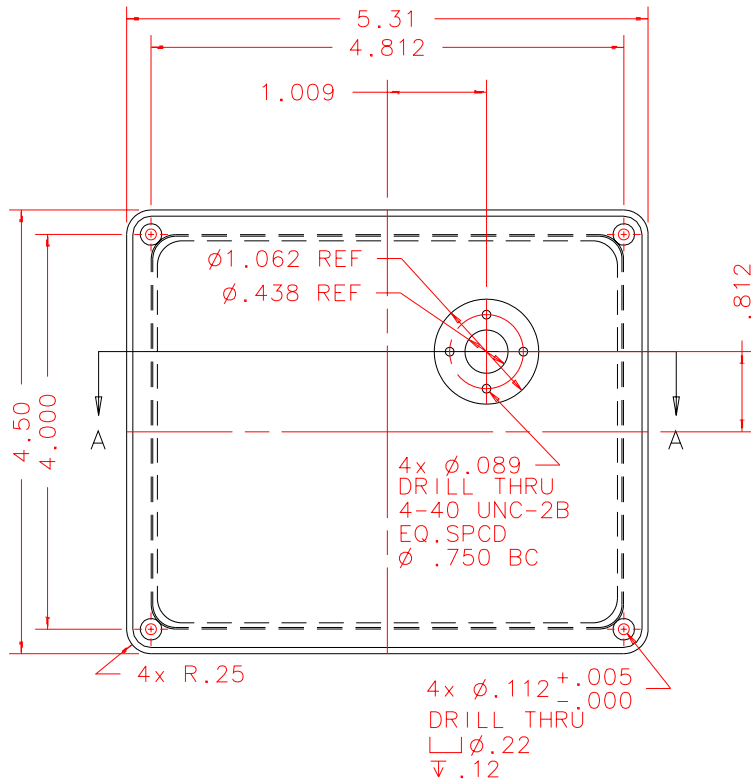

FRONT: SCALE 1:2

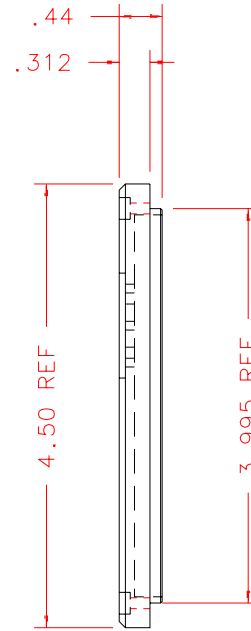

RIGHT
SCALE 1:2

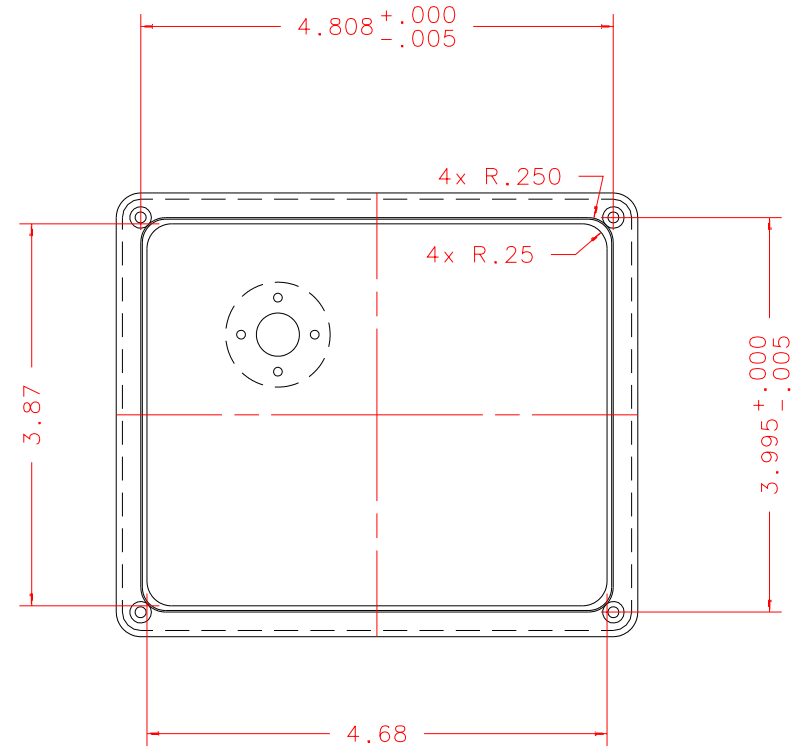

BACK: SCALE 1:2

PLOT: 10/19/99

SF8-001B
NEXT ASSY

REVDATE: N/A	REVISION: N/A
DATE: 12/28/98	INSTITUTE FOR ASTRONOMY 2680 WOODLAWN DR. HONOLULU, HI 96822
DESIGN: STAHLBERGER	
DRAWN: STAHLBERGER	
APPR'D: J. RAYNER	
TOLERANCES	
X.X	+/- .015
X.XX	+/- .005
X.XXX	+/- .002
ANGLE	+/- 30 min
FRACTION	+/- 1/32
INSTRUMENT: SPEX - CROSS DISPERSED SPECTROGRAPH	
PART NAME: ACCESS COVER	
TELESCOPE: IRTF	
DRW NO: SF8-011A	SCALE: NOTED
SIZE: A	JOS NO: 725
SHEET: 1 OF 2	