

NOTES: UNLESS OTHERWISE NOTED

1. MACHINED SURFACE ROUGHNESS 64
- 0-RING GROOVES AND SURFACES 32
2. REMOVE ALL BURRS/SHARP CORNERS

BILL OF MATERIAL				
NO.	REQ'D	REF DRW	DESCRIPTION	MATERIAL
N/A	1	SF8-016A	BAFFLE TUBE MALE	ALU 6061-T6

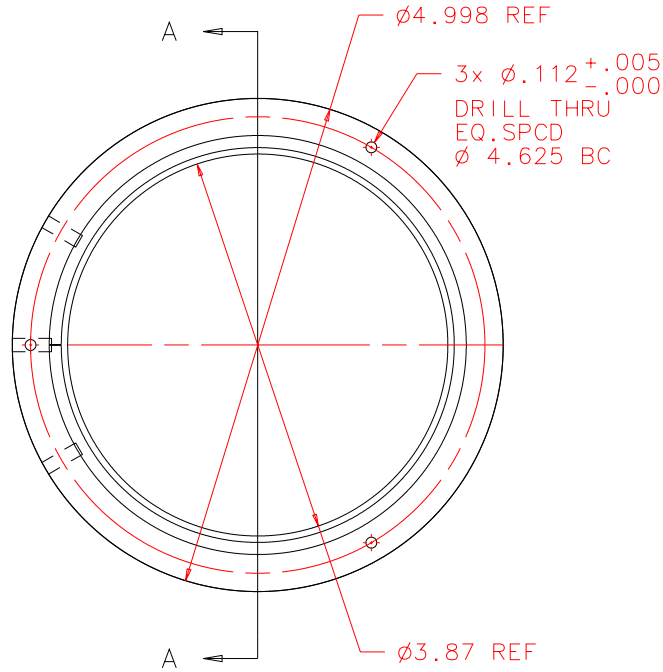

FRONT

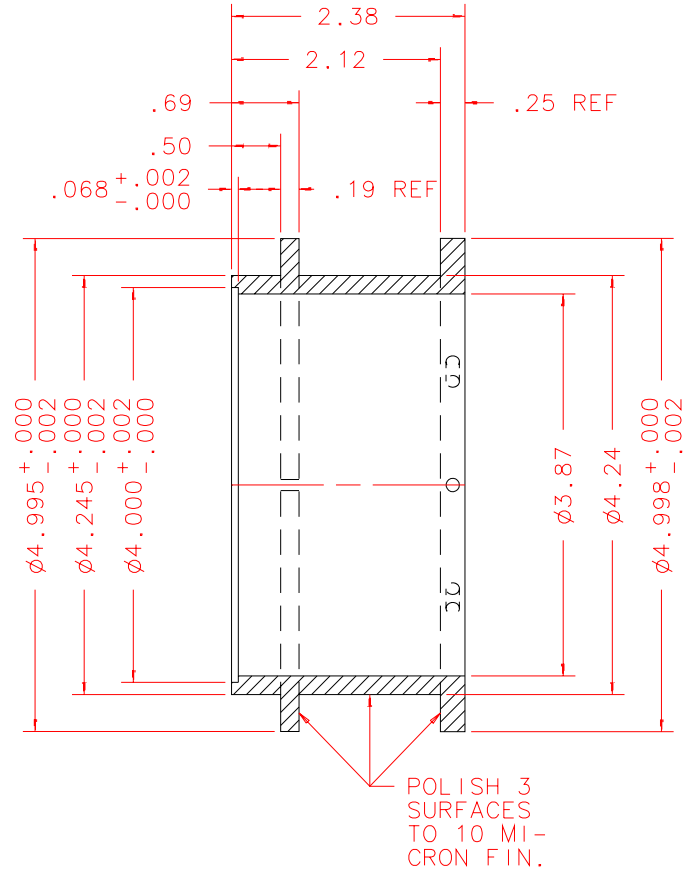

SECTION A-A

REVDATE: 10/15/99	REVISION: ADD THIRD 8-32 HOLE
REVDATE: N/A	REVISION: N/A
DATE: 01/04/99	<b>INSTITUTE FOR ASTRONOMY</b>
DESIGN: STAHLBERGER	2680 WOODLAWN DR. HONOLULU, HI 96822
DRAWN: STAHLBERGER	INSTRUMENT: SPEX - CROSS DISPERSED SPECTROGRAPH
APPR'D: J. RAYNER	PART NAME: BAFFLE TUBE MALE
<b>TOLERANCES</b>	
X.X	+/- .015
X.XX	+/- .005
X.XXX	+/- .002
ANGLE	+/- 30 min
FRACTION	+/- 1/32
TELESCOPE: IRTF	
DRW NO: SF8-016A	SCALE: 1:2
SIZE: A	JOS NO: 725
NEXT ASSY	SHEET: 1 OF 2

PLOT: 10/19/99