

NOTES: UNLESS OTHERWISE NOTED

1. MACHINED SURFACE ROUGHNESS 64  
O-RING GROOVES AND SURFACES 32
2. REMOVE ALL BURRS/SHARP CORNERS

BILL OF MATERIAL				
NO.	REQ'D	REF DRW	DESCRIPTION	MATERIAL
N/A	3	SF8-027A	PK-50 CLIP	PHOS. BRONZE

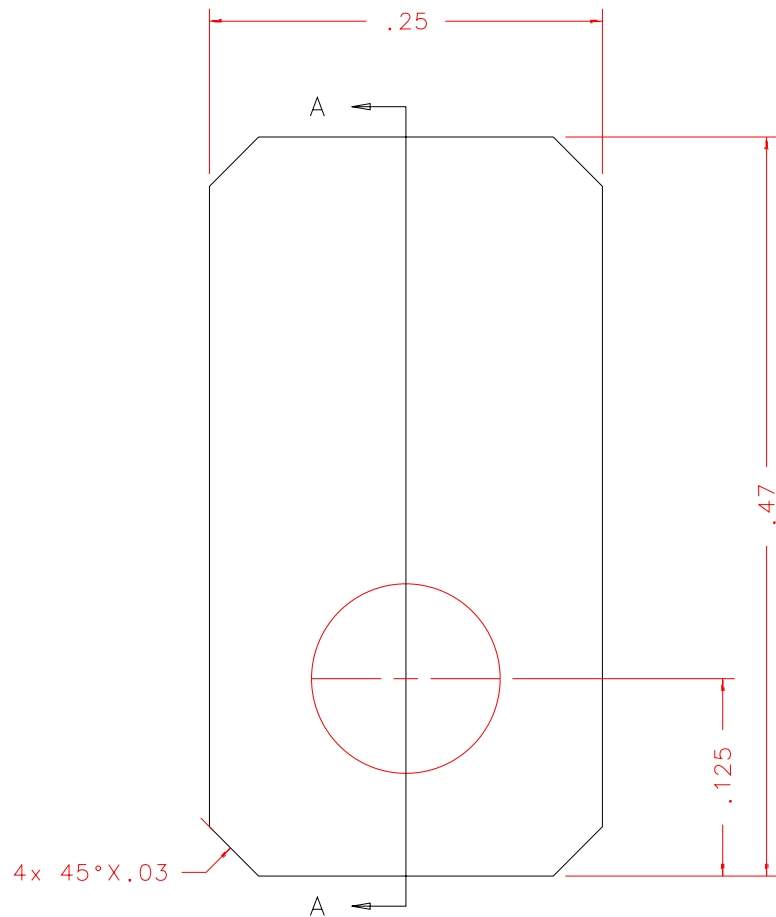

FRONT

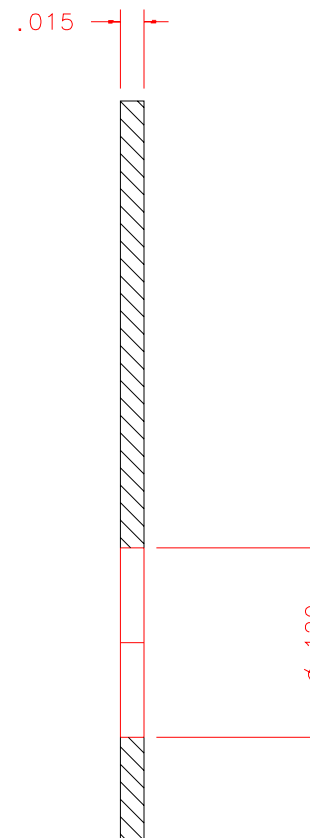

SECTION A-A

PLOT: 10/19/99

SF8-001B  
NEXT ASSY

REVDATE: N/A	REVISION: N/A
DATE: 01/04/99	<b>INSTITUTE FOR ASTRONOMY</b>
DESIGN: STAHLBERGER	2680 WOODLAWN DR. HONOLULU, HI 96822
DRAWN: STAHLBERGER	INSTRUMENT: SPEX - CROSS DISPERSED SPECTROGRAPH
APPR'D: J. RAYNER	PART NAME: PK-50 CLIP
<b>TOLERANCES</b>	TELESCOPE: IRTF
X.X +/- .015	DRW NO: SF8-027A
X.XX +/- .005	SCALE: 8:1
X.XXX +/- .002	SIZE: A
ANGLE +/- 30 min	JOS NO: 725
FRACTION +/- 1/32	SHEET: 1 OF 1