

NOTES: UNLESS OTHERWISE NOTED

1. MACHINED SURFACE ROUGHNESS 64
O-RING GROOVES AND SURFACES 32
2. REMOVE ALL BURRS/SHARP CORNERS

BILL OF MATERIAL

NO.	REQ'D	REF DRW	DESCRIPTION	MATERIAL
N/A	1	SF8-034A	BAFFLE TUBE FIXED 2 INSERT	ALU 6061-T6

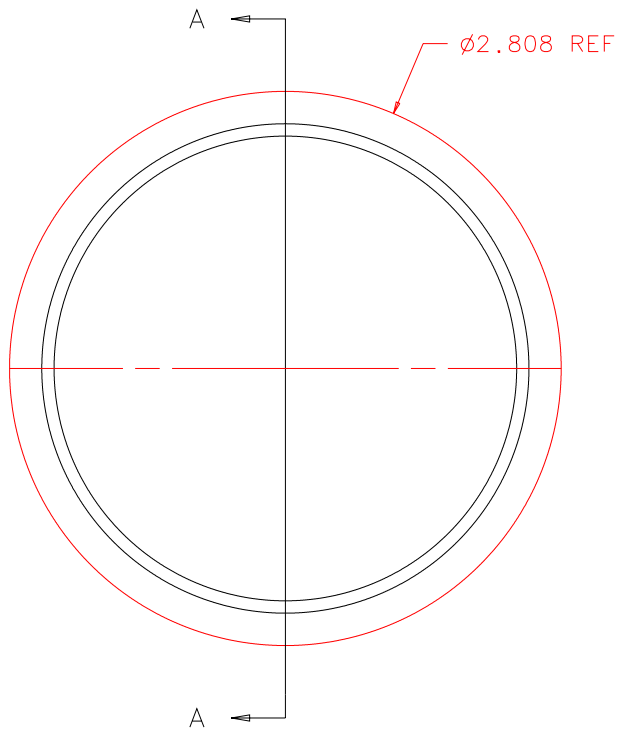

FRONT

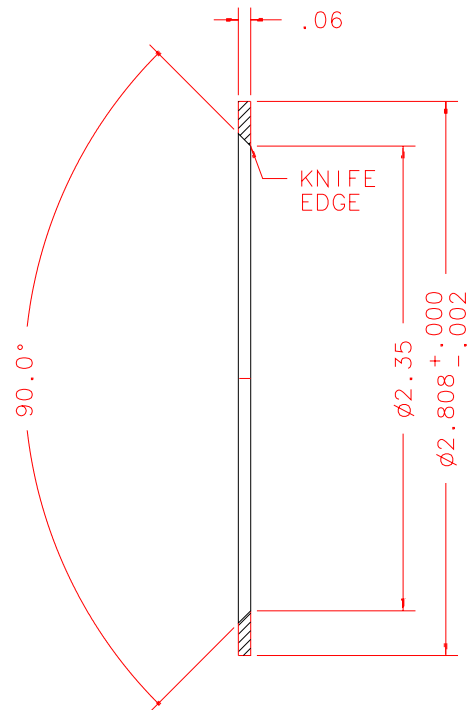

SECTION A-A

REVDATE: 10/15/99	REVISION: CHANGED FROM SQUARE TO ROUND
REVDATE: N/A	REVISION: N/A
DATE: 01/04/99	INSTITUTE FOR ASTRONOMY 2680 WOODLAWN DR. HONOLULU, HI 96822
DESIGN: STAHLBERGER	
DRAWN: STAHLBERGER	INSTRUMENT: SPEX - CROSS DISPERSED SPECTROGRAPH
APPR'D: J. RAYNER	PART NAME: BAFFLE TUBE FIXED 2 INSERT
TOLERANCES	
X.X	+/- .015
X.XX	+/- .005
X.XXX	+/- .002
ANGLE	+/- 30 min
FRACTION	+/- 1/32
DRW NO: SF8-034A	SCALE: 1:1
SIZE: A	JOS NO: 725
SHEET: 1 OF 1	

PLOT: 10/19/99

SF8-001B
NEXT ASSY