

NOTES: UNLESS OTHERWISE NOTED

1. MACHINED SURFACE ROUGHNESS 64
O-RING GROOVES AND SURFACES 32
2. REMOVE ALL BURRS/SHARP CORNERS

| BILL OF MATERIAL | | | | |
|------------------|-------|----------|-------------|---------------|
| NO. | REQ'D | REF DRW | DESCRIPTION | MATERIAL |
| N/A | 1 | SPO-026A | SHAFT | STAINLESS 303 |

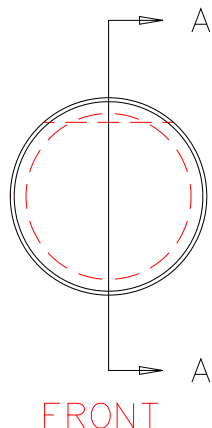
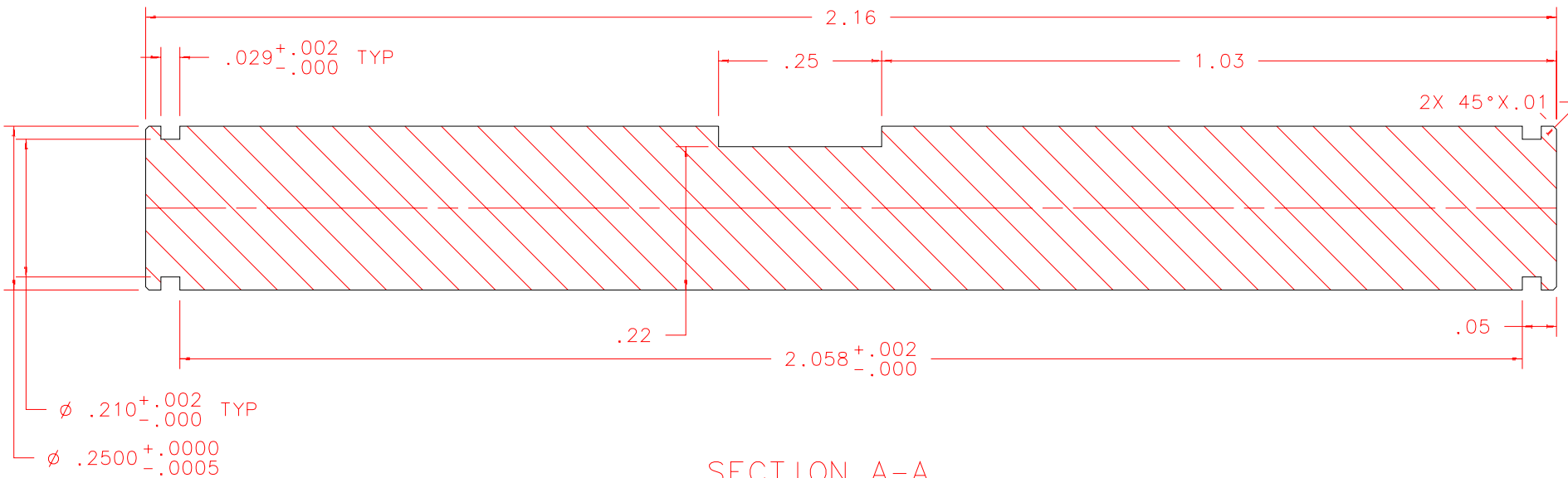

| | |
|---------------------|--|
| REVDATE: N/A | REVISION: N/A |
| DATE: 05/07/97 | INSTITUTE FOR ASTRONOMY 2680 WOODLAWN DR. HONOLULU, HI 96822 |
| DESIGN: STAHLBERGER | |
| DRAWN: STAHLBERGER | INSTRUMENT: SPEX - CROSS DISPERSED SPECTROGRAPH |
| APPR'D: J. RAYNER | PART NAME: SHAFT |
| TOLERANCES | |
| X.X | +/- .015 |
| X.XX | +/- .005 |
| X.XXX | +/- .002 |
| ANGLE | +/- 30 min |
| FRACTION | +/- 1/32 |
| DRW NO: SPO-026A | SCALE: 4:1 |
| SIZE: A | JOS NO: 725 |
| SHEET: 1 OF 1 | |

PLOT: 10/19/99

SPO-001B
NEXT ASSY