

NOTES: UNLESS OTHERWISE NOTED

1. MACHINED SURFACE ROUGHNESS 64  
O-RING GROOVES AND SURFACES 32
2. REMOVE ALL BURRS/SHARP CORNERS

BILL OF MATERIAL				
NO.	REQ'D	REF DRW	DESCRIPTION	MATERIAL
N/A	2	SP0-034A	FILTER SHAFT LIGHT COVER	ALU 6061-T6

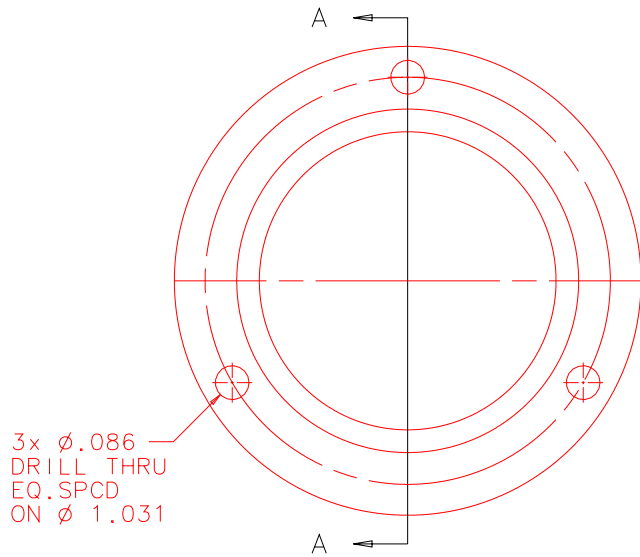

FRONT: SCALE 2:1

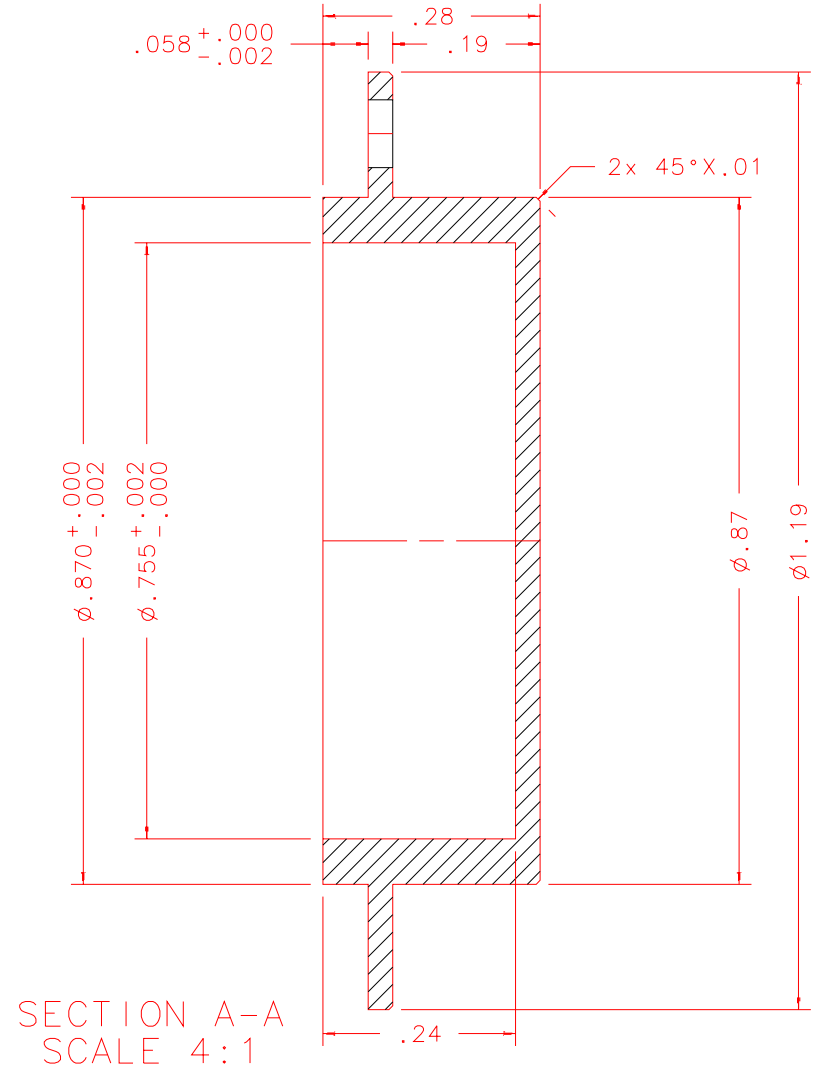

SECTION A-A  
SCALE 4:1

REVDATE: N/A	REVISION: N/A
DATE: 11/16/98	<b>INSTITUTE FOR ASTRONOMY</b>
DESIGN: STAHLBERGER	2680 WOODLAWN DR. HONOLULU, HI 96822
DRAWN: STAHLBERGER	INSTRUMENT: SPEX - CROSS DISPERSED SPECTROGRAPH
APPR'D: J. RAYNER	PART NAME: FILTER SHAFT LIGHT COVER
<b>TOLERANCES</b>	
X.X	+/- .015
X.XX	+/- .005
X.XXX	+/- .002
ANGLE	+/- 30 min
FRACTION	+/- 1/32
TELESCOPE: IRTF	
DRW NO: SP0-034A	SCALE: NOTED
SIZE: A	JOS NO: 725
	SHEET: 1 OF 1

PLOT: 10/19/99

SP0-001BN  
NEXT ASSY