

NOTES: UNLESS OTHERWISE NOTED

1. MACHINED SURFACE ROUGHNESS 64
2. O-RING GROOVES AND SURFACES 32
3. REMOVE ALL BURRS/SHARP CORNERS

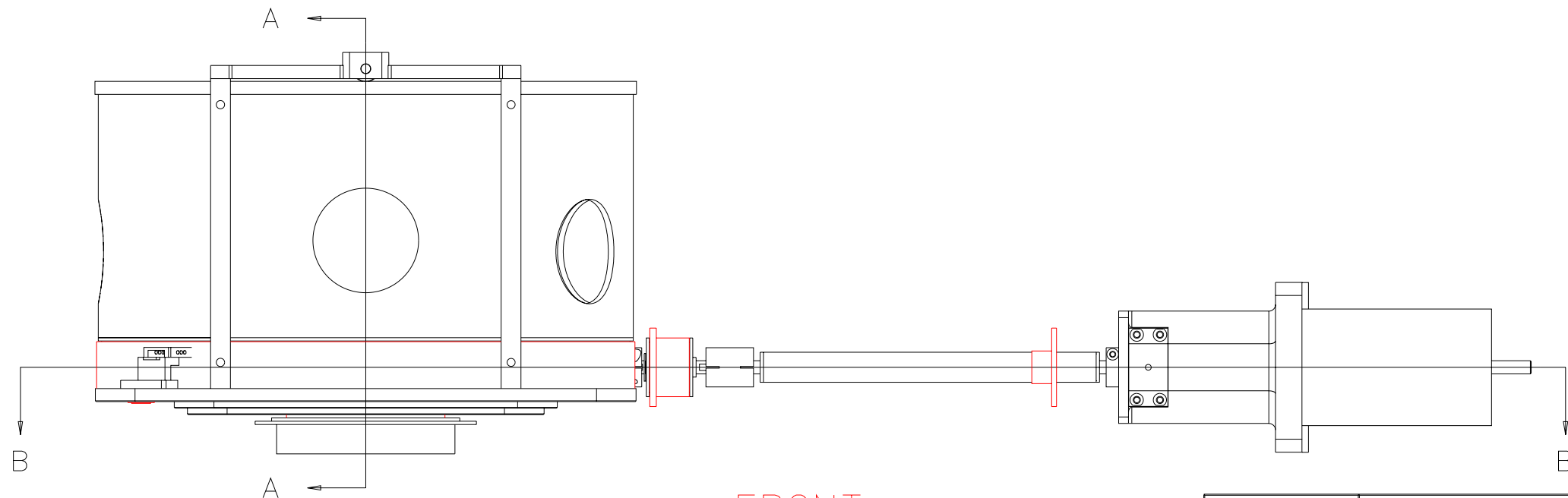
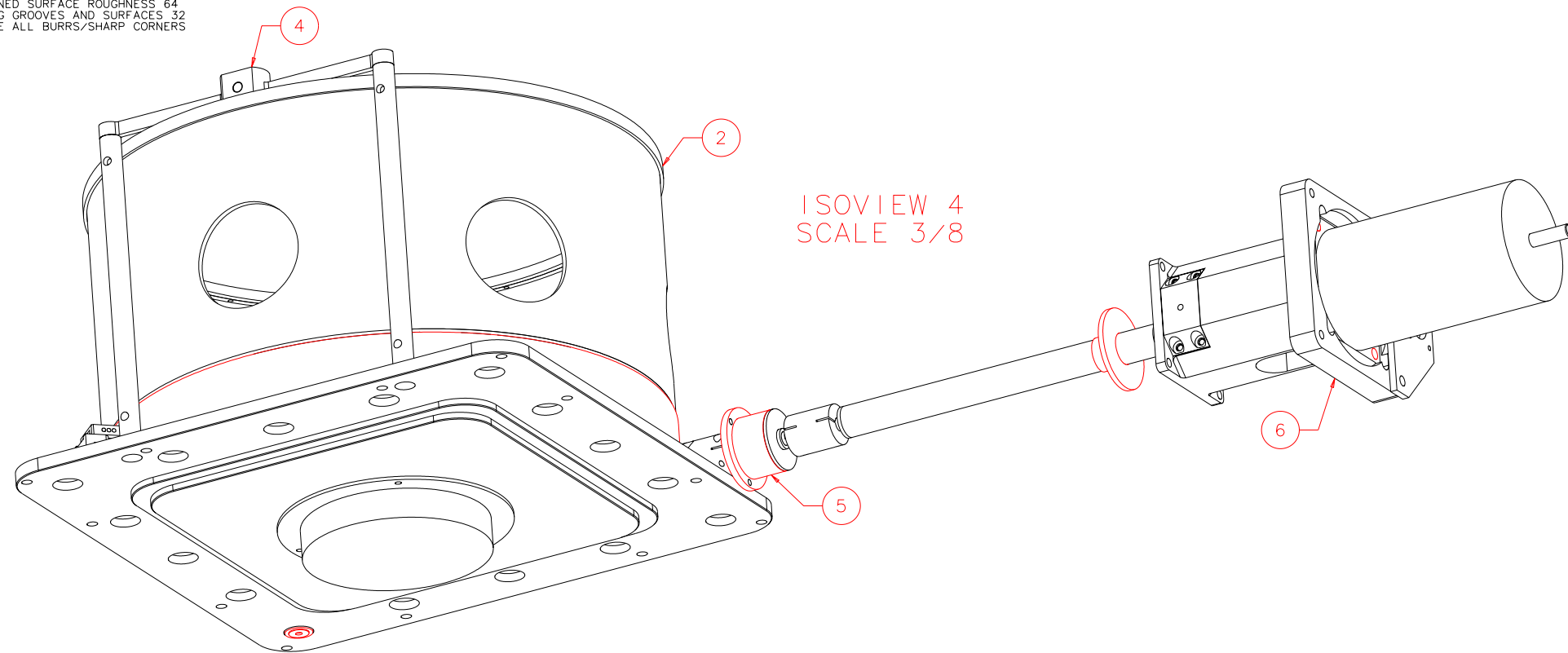

BILL OF MATERIAL					
NO.	REQ'D	REF DRW	DESCRIPTION	MATERIAL	
N/A	1	SK0-001B	GRATING TURRET	N/A	
1	1	SK1-001B	BEARING MOUNT (ASSEMBLY)	N/A	
2	1	SK2-001B	DRUM (ASSEMBLY)	N/A	
3	1	SK3-001B	FLEX DRIVE (ASSEMBLY)	N/A	
4	1	SK4-001B	GUIDE BEARING (ASSEMBLY)	N/A	
5	1	SP4-001A	LIGHT SHIELD (ASSEMBLY)	N/A	
6	1	SP5-001A	WARM MOTOR	N/A	

REVDATE: 05/24/99	REVISION: UPDATE: REDESIGNED FLEX STAGE
REVDATE: 02/05/99	REVISION: UPDATE DRAWING
REVDATE: N/A	REVISION: N/A
DATE: 01/27/98	INSTITUTE FOR ASTRONOMY
DESIGN: STAHLBERGER	2680 WOODLAWN DR. HONOLULU, HI 96822
DRAWN: STAHLBERGER	INSTRUMENT: SPEX - CROSS DISPERSED SPECTROGRAPH
APPR'D: J. RAYNER	PART NAME: GRATING TURRET
TOLERANCES	TELESCOPE: IRTF
X.X +/- .015	
X.XX +/- .005	
X.XXX +/- .002	
ANGLE +/- 30 min	
FRACTION +/- 1/32	
S00-001B	DRW NO: SK0-001B
NEXT ASSY	SCALE: NOTED
	SIZE: B
	JOS NO: 725
	SHEET: 1 OF 3

PLOT: 10/19/99