

NOTES: UNLESS OTHERWISE NOTED  
 1. MACHINED SURFACE ROUGHNESS 64  
 O-RING GROOVES AND SURFACES 32  
 2. REMOVE ALL BURRS/SHARP CORNERS

BILL OF MATERIAL				
NO.	REQ'D	REF DRW	DESCRIPTION	MATERIAL
N/A	1	SK2-001B	DRUM	N/A
1	1	SK2-011B	BASE PLATE	ALU 6061-T6
2	3	N/A	BELLVILLE WASHER ST-4(BERG)	STAINLESS
3	16	SK2-012A	DELTRIN LIGHT PLUG	BLACK DELRIN
4	1	SK2-013B	DRUM	ALU 6061-T6
5	1	SK2-014B	DRUM COVER	ALU 6061-T6
6	1	SK2-015B	DUST COVER(MAKE AT IFA)	ALU 6061-T6
7	1	SK2-016A	HALL SENSOR BRACKET	ALU 6061-T6
8	1	SJ4-017A	HALL SENSOR CARRIER	ALU 6061-T6
9	1	SK2-017A	LIGHT SHIELD	ALU 6061-T6
10	1	SK2-018B	OPTICS BENCH	ALU 6061-T6
11	1	SK2-019A	TIE SEGMENT	ALU 6061-T6

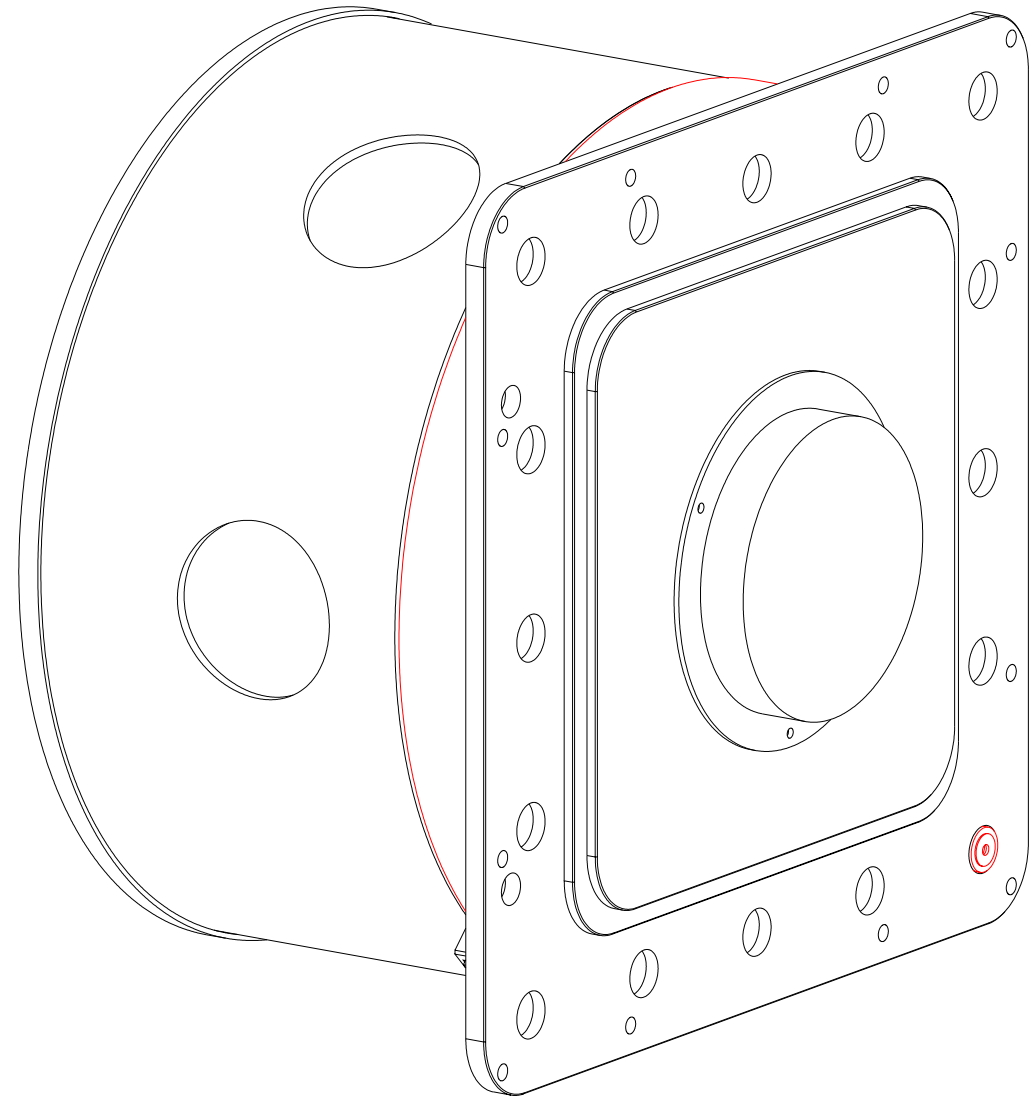

ISOVIEW 3  
SCALE 1:2

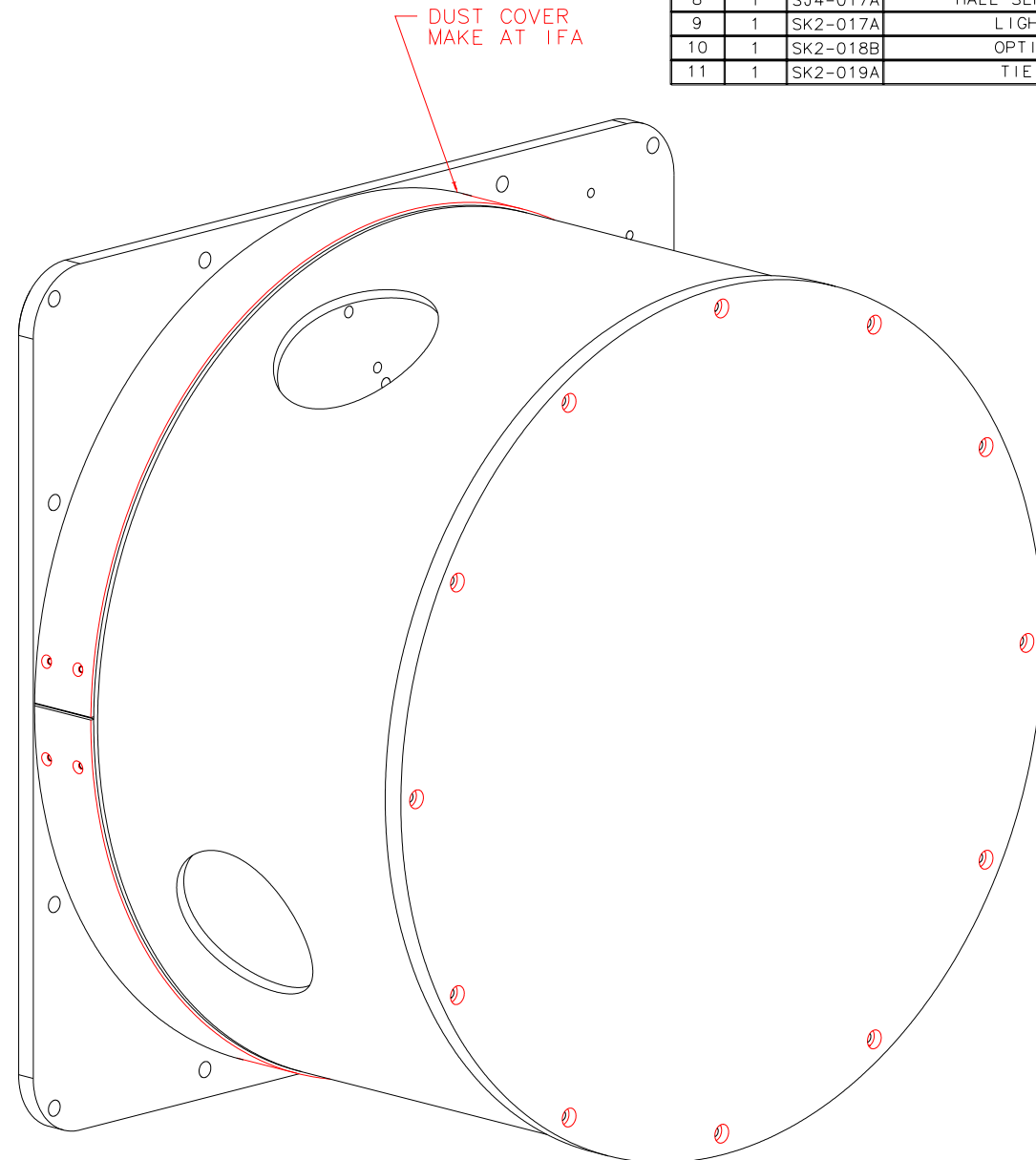

ISOVIEW 2  
SCALE 1:2

REVD: N/A	REVISION: N/A
DATE: 01/23/98	<b>INSTITUTE FOR ASTRONOMY</b>
DESIGN: STAHLBERGER	2680 WOODLAWN DR. HONOLULU, HI 96822
DRAWN: STAHLBERGER	INSTRUMENT: SPEX - CROSS DISPERSED SPECTROGRAPH
APPR'D: J. RAYNER	PART NAME: DRUM
<b>TOLERANCES</b>	
X.X	+/- .015
X.XX	+/- .005
X.XXX	+/- .002
ANGLE	+/- 30 min
FRACTION	+/- 1/32
SK0-001B	DRW NO: SK2-001B
NEXT ASSY	SCALE: NOTED
SIZE: B	JOS NO: 725
	SHEET: 2 OF 2