

NOTES: UNLESS OTHERWISE NOTED

1. MACHINED SURFACE ROUGHNESS 64
O-RING GROOVES AND SURFACES 32
2. REMOVE ALL BURRS/SHARP CORNERS

BILL OF MATERIAL				
NO.	REQ'D	REF DRW	DESCRIPTION	MATERIAL
N/A	1	SK5-013A	SXD1 FRONT BAFFLE	ALU 6061-T6

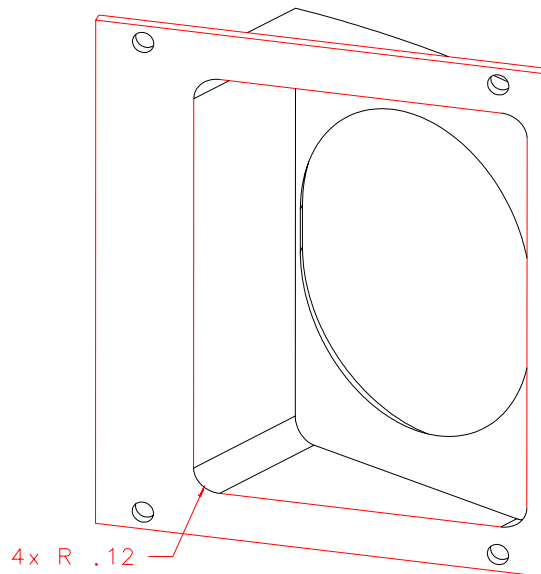

4x R .12

ISOVIEW 7

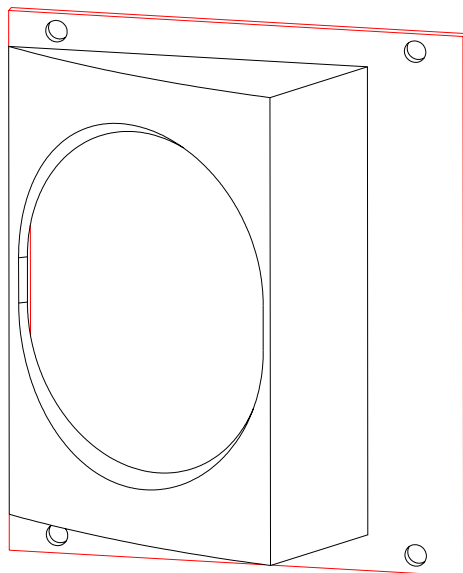

ISOVIEW 8

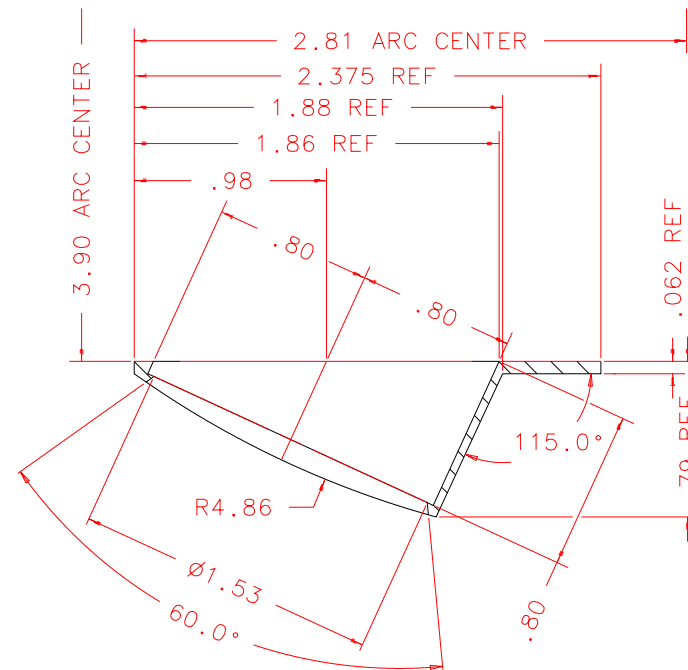

SECTION A-A

PLOT: 10/19/99

SK5-001B	REVISION: ROUND HOLE MADE ELONGATED .24	DRW NO: SK5-013A	SCALE: 1:1
NEXT ASSY	REVISION: N/A	SIZE: A	JOS NO: 725
	DATE: 06/24/99	SHEET: 2 OF 2	
	DESIGN: STAHLBERGER	INSTITUTE FOR ASTRONOMY	
	DRAWN: STAHLBERGER	2680 WOODLAWN DR. HONOLULU, HI 96822	
	APPR'D: J. RAYNER	INSTRUMENT: SPEX - CROSS DISPERSED SPECTROGRAPH	
		PART NAME: SXD1 FRONT BAFFLE	
		TELESCOPE: IRTF	