

NOTES: UNLESS OTHERWISE NOTED

1. MACHINED SURFACE ROUGHNESS 64  
O-RING GROOVES AND SURFACES 32
2. REMOVE ALL BURRS/SHARP CORNERS

BILL OF MATERIAL				
NO.	REQ'D	REF DRW	DESCRIPTION	MATERIAL
N/A	3	SK5-026A	GRATING CLIP	PHOS. BRONZE

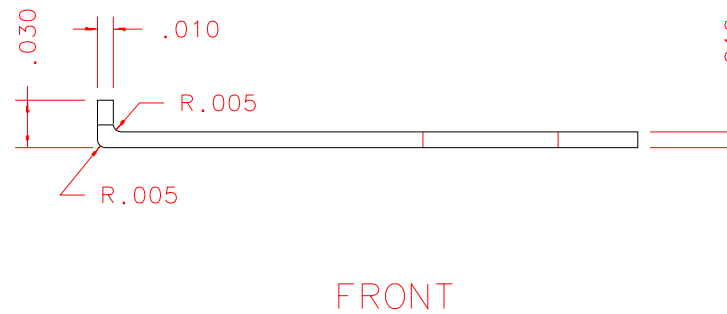
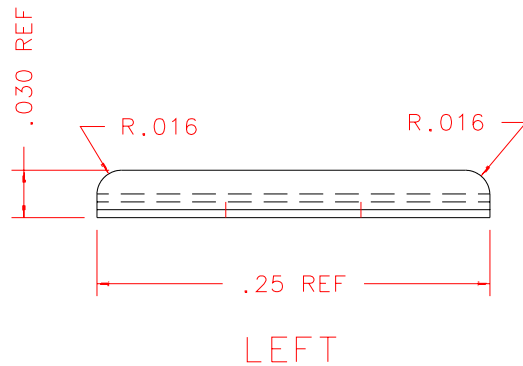
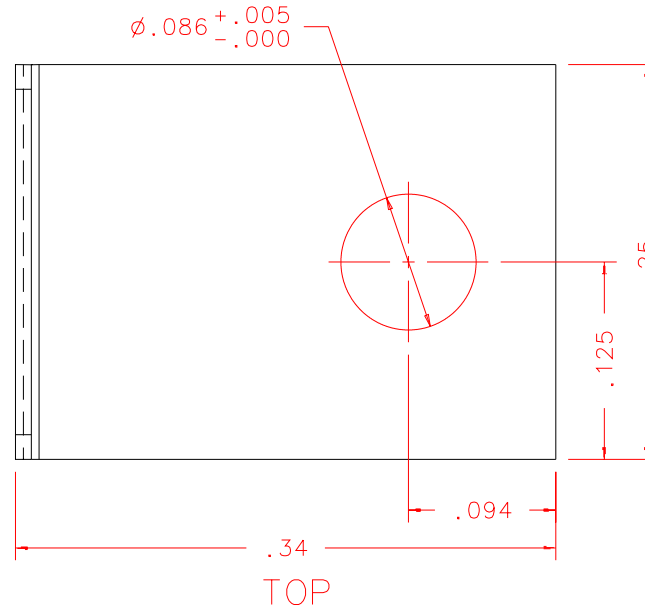

REVDATE: N/A	REVISION: N/A
DATE: 06/22/99	<b>INSTITUTE FOR ASTRONOMY</b> 2680 WOODLAWN DR. HONOLULU, HI 96822
DESIGN: STAHLBERGER	
DRAWN: STAHLBERGER	
APPR'D: J. RAYNER	
<b>TOLERANCES</b>	
X.X	+/- .015
X.XX	+/- .005
X.XXX	+/- .002
ANGLE	+/- 30 min
FRACTION	+/- 1/32
INSTRUMENT: SPEX - CROSS DISPERSED SPECTROGRAPH	
PART NAME: GRATING CLIP	
TELESCOPE: IRTF	
DRW NO: SK5-026A	SCALE: 8:1
SIZE: A	JOS NO: 725
SHEET: 1 OF 1	

SK5-001B
NEXT ASSY

PLOT: 10/19/99