

NOTES: UNLESS OTHERWISE NOTED  
 1. MACHINED SURFACE ROUGHNESS 64  
 O-RING GROOVES AND SURFACES 32  
 2. REMOVE ALL BURRS/SHARP CORNERS

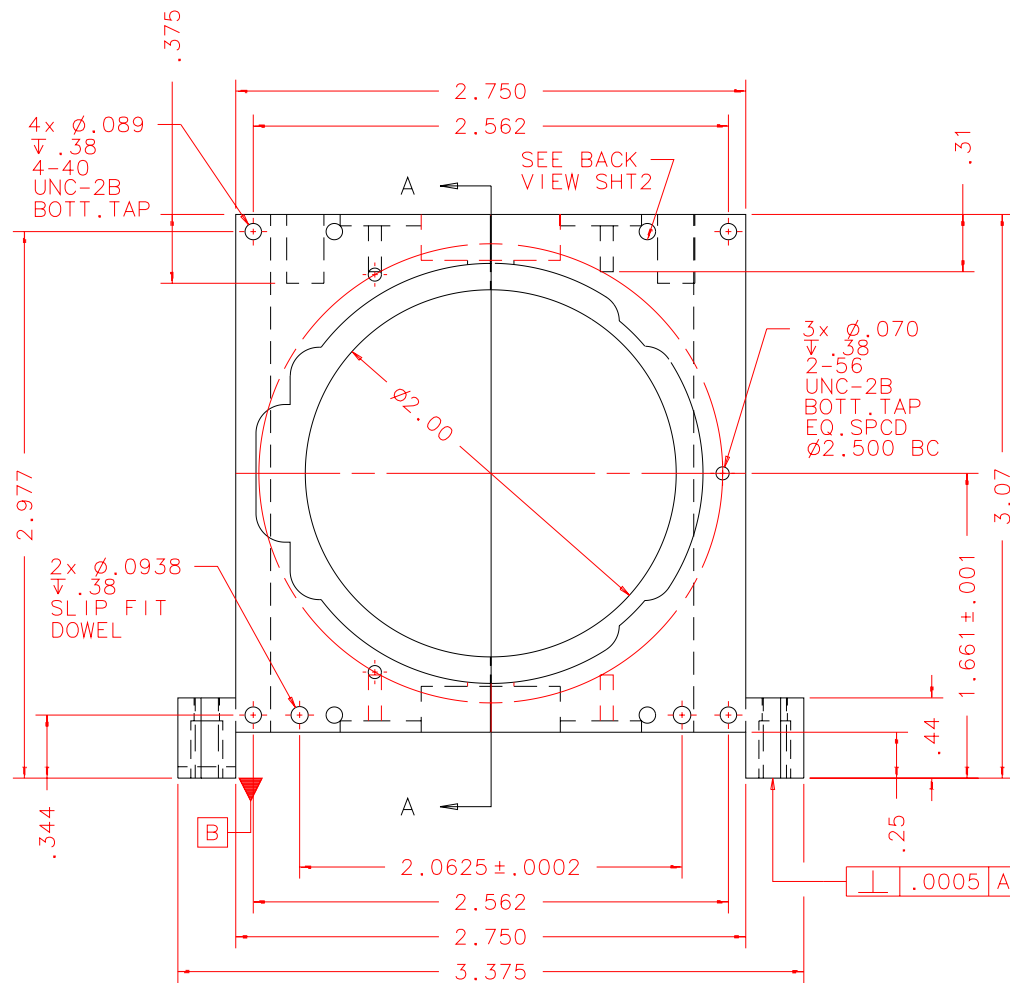

BILL OF MATERIAL				
NO.	REQ'D	REF DRW	DESCRIPTION	MATERIAL
N/A	1	SK8-014B	LXD1 PRISM MOUNT	ALU 6061-T6

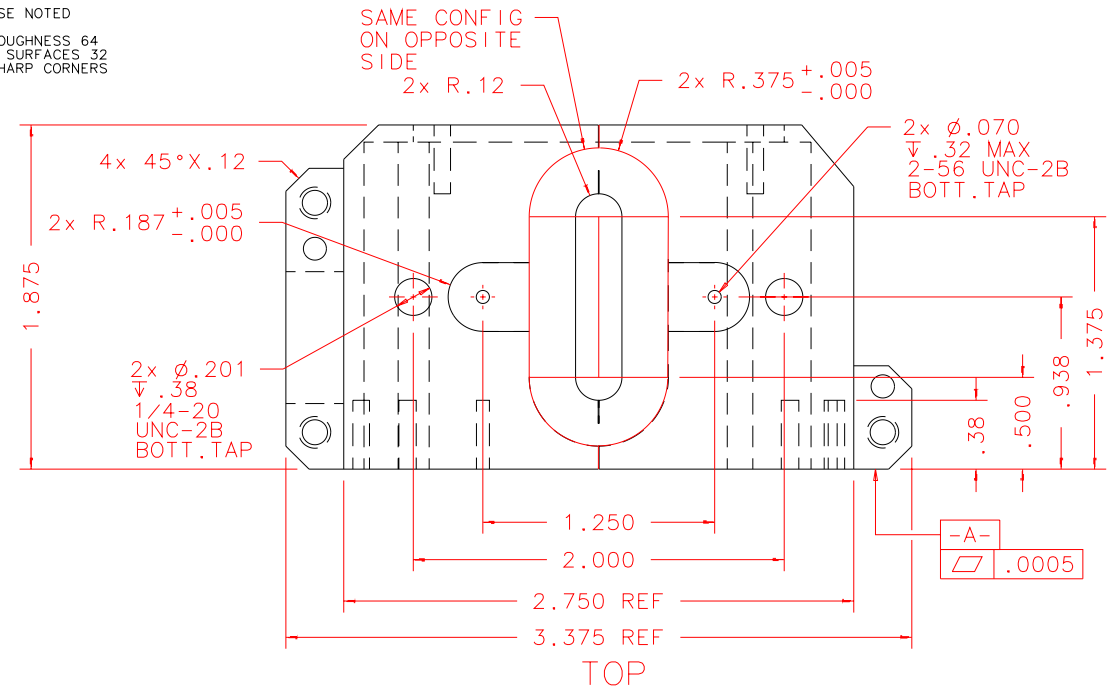
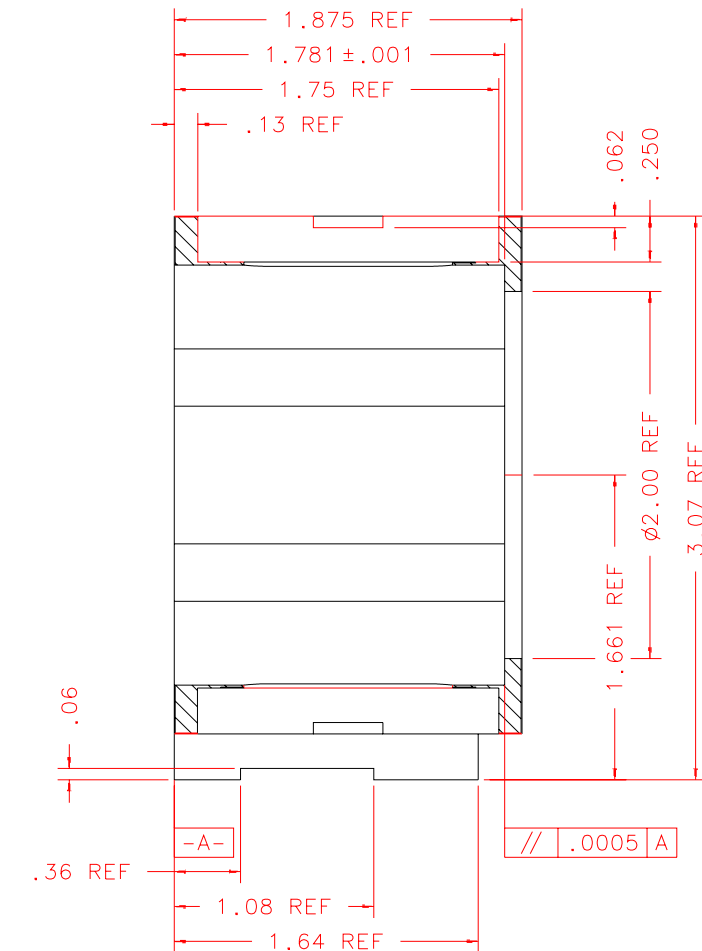

SECTION A-A

PLOT: 10/19/99

SK8-001B	REVISION: N/A	INSTITUTE FOR ASTRONOMY
NEXT ASSY	DATE: 09/03/99	2680 WOODLAWN DR. HONOLULU, HI 96822
	DESIGN: STAHLBERGER	INSTRUMENT: SPEX - CROSS DISPERSED SPECTROGRAPH
	DRAWN: STAHLBERGER	PART NAME: LX1 PRISM MOUNT
	APPR'D: J. RAYNER	TELESCOPE: IRTF
	<b>TOLERANCES</b>	
	X.X +/- .015	DRW NO: SK8-014B
	X.XX +/- .005	SCALE: 1:1
	X.XXX +/- .002	SIZE: B
	ANGLE +/- 30 min	JOS NO: 725
	FRACTION +/- 1/32	SHEET: 1 OF 3