

NOTES: UNLESS OTHERWISE NOTED
 1. MACHINED SURFACE ROUGHNESS 64
 O-RING GROOVES AND SURFACES 32
 2. REMOVE ALL BURRS/SHARP CORNERS

BILL OF MATERIAL				
NO.	REQ'D	REF DRW	DESCRIPTION	MATERIAL
N/A	1	SK8-014B	LXD1 PRISM MOUNT	ALU 6061-T6

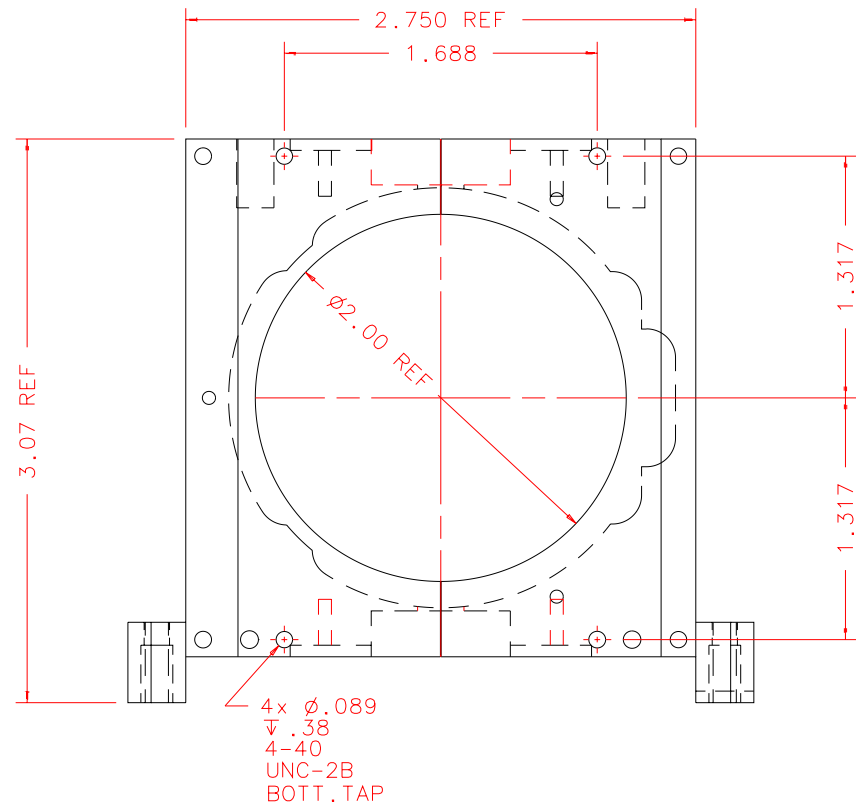
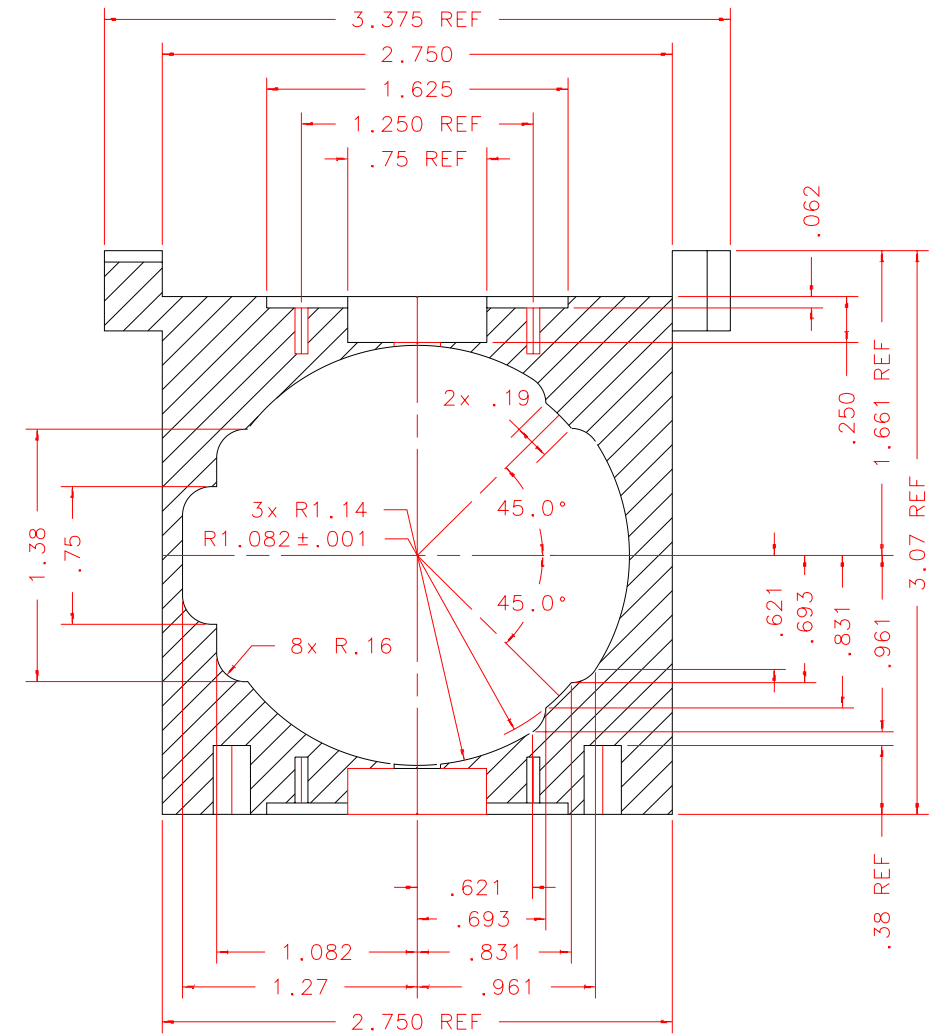
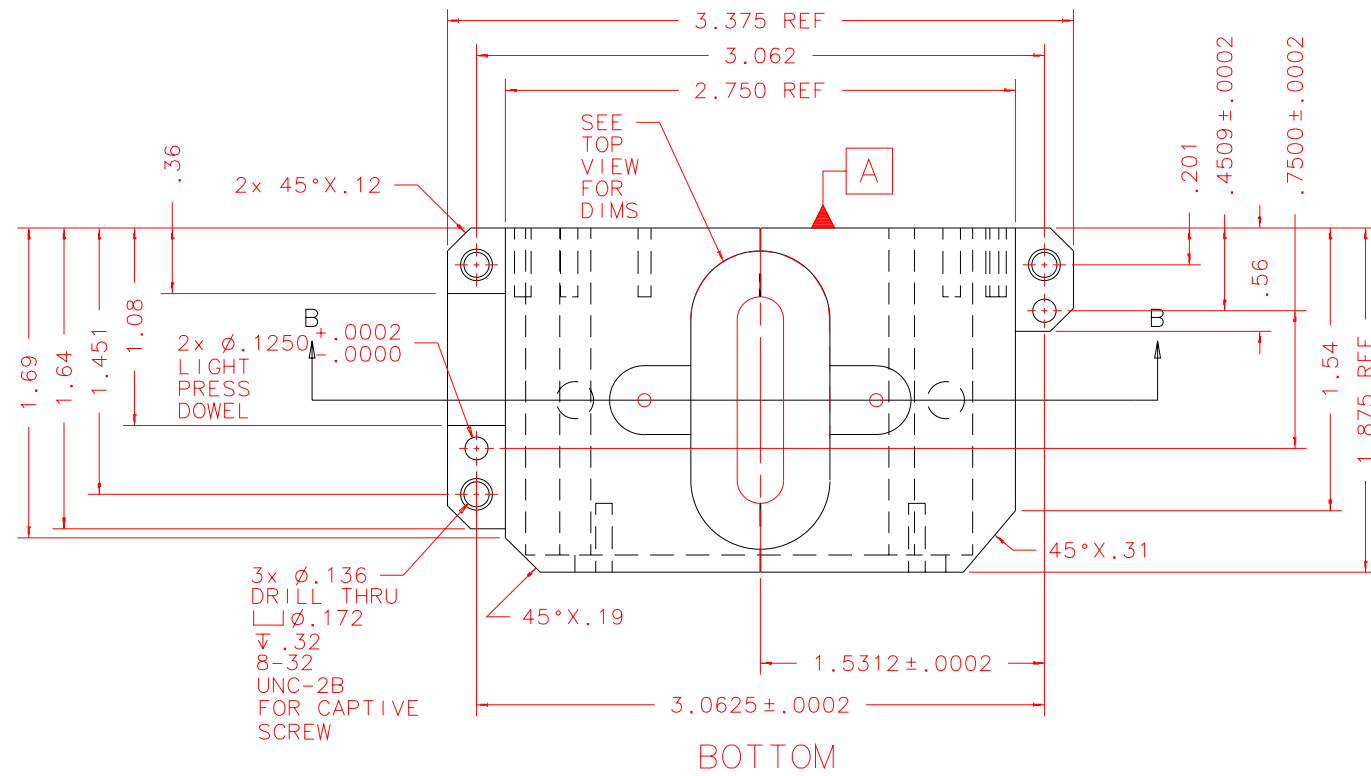

SECTION B-B

PLOT: 10/19/99

SK8-001B	REVD: N/A	REVISION: N/A	INSTITUTE FOR ASTRONOMY 2680 WOODLAWN DR. HONOLULU, HI 96822
NEXT ASSY	DATE: 09/03/99	DESIGN: STAHLBERGER	
	DRAWN: STAHLBERGER	INSTRUMENT: SPEX - CROSS DISPERSED SPECTROGRAPH	PART NAME: LX1D1 PRISM MOUNT TELESCOPE: IRTF
	APPR'D: J. RAYNER	DRW NO: SK8-014B	
	TOLERANCES		SCALE: 1:1
	X.X	+/- .015	SIZE: B
	X.XX	+/- .005	
	X.XXX	+/- .002	JOS NO: 725
	ANGLE	+/- 30 min	
	FRACTION	+/- 1/32	SHEET: 2 OF 3