

NOTES: UNLESS OTHERWISE NOTED
 1. MACHINED SURFACE ROUGHNESS 64
 O-RING GROOVES AND SURFACES 32
 2. REMOVE ALL BURRS/SHARP CORNERS

TOLERANCES: UNLESS MARKED OTHERWISE
 X.XXXX +/- .0005

BILL OF MATERIAL				
NO.	REQ'D	REF DRW	DESCRIPTION	MATERIAL
N/A	1	SG11-018B	K-MIRROR SUPPORT	ALU 6061-T6

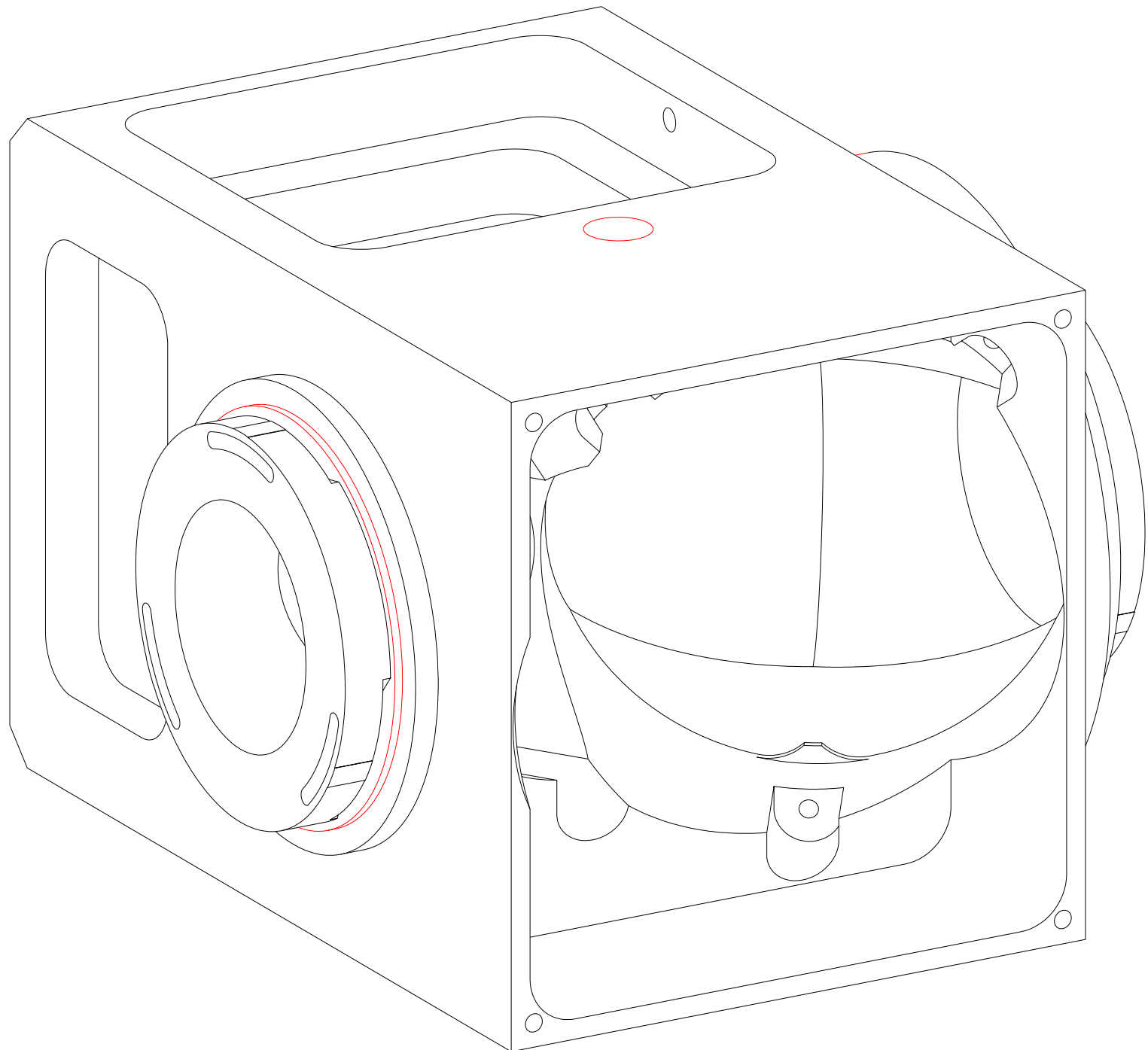

ISOVIEW6: SCALE 2:1

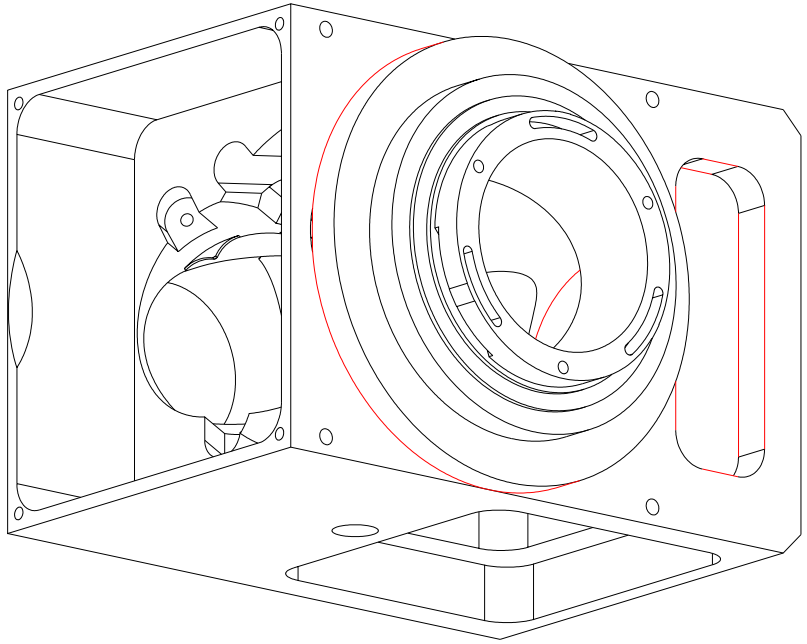

ISOVIEW7: SCALE 1:1

REVDATE: 01/26/99	REVISION: ADD 1/8 CHAMFER SHEET2
REVDATE: 12/02/98	REVISION: ADD WEIGHT RELIEF POCKETS
REVDATE: 10/12/98	REVISION: ADD DIMS IN SHEET 1 LEFT VIEW
REVDATE: N/A	REVISION: N/A
DATE: 04/24/98	INSTITUTE FOR ASTRONOMY
DESIGN: STAHLBERGER	2680 WOODLAWN DR. HONOLULU, HI 96822
DRAWN: STAHLBERGER	INSTRUMENT: SPEX - CROSS DISPERSED SPECTROGRAPH
APPR'D: J. RAYNER	PART NAME: K-MIRROR SUPPORT
TOLERANCES	TELESCOPE: IRTF
X.X +/- .015	
X.XX +/- .005	
X.XXX +/- .002	
ANGLE +/- 30 min	
FRACTION +/- 1/32	
SG11-001B	DRW NO: SG11-018B
NEXT ASSY	SCALE: NOTED
	SIZE: B
	JOS NO: 725
	SHEET: 7 OF 8