

NOTES: UNLESS OTHERWISE NOTED  
 1. MACHINED SURFACE ROUGHNESS 64  
 O-RING GROOVES AND SURFACES 32  
 2. REMOVE ALL BURRS/SHARP CORNERS

BILL OF MATERIAL				
NO.	REQ'D	REF DRW	DESCRIPTION	MATERIAL
NAAL	6061	SG3-016B	OPTICS BENCH	ALU 6061-T6

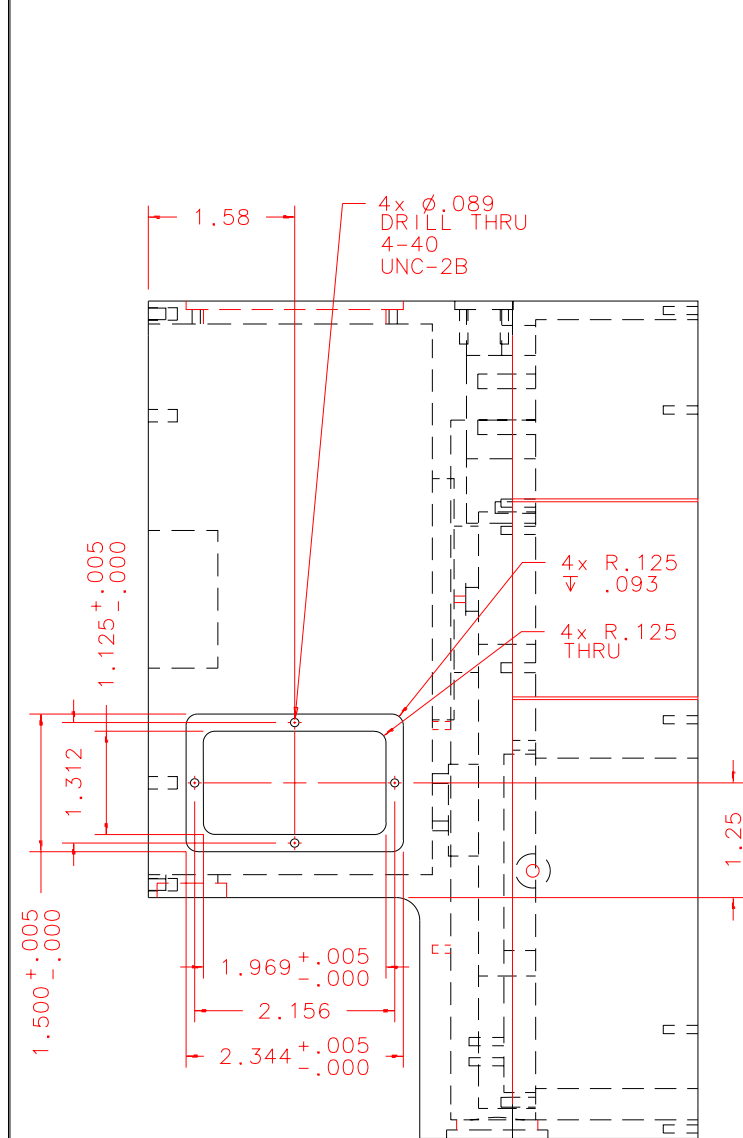

LEFT: SCALE 1:2

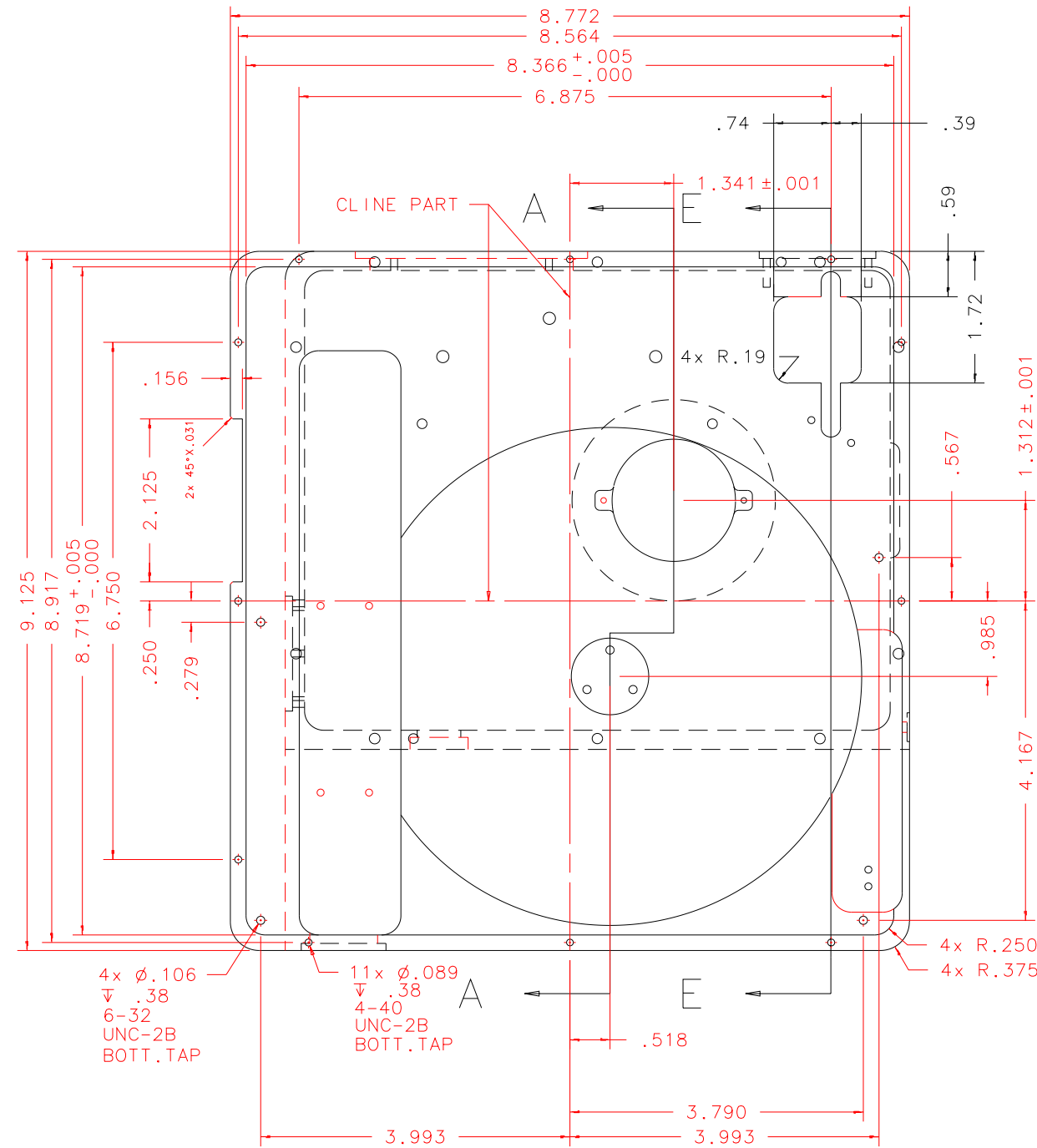

FRONT: SCALE 1:2  
 SEE ALSO SHEET 6&7  
 FOR DUPLICATE VIEW

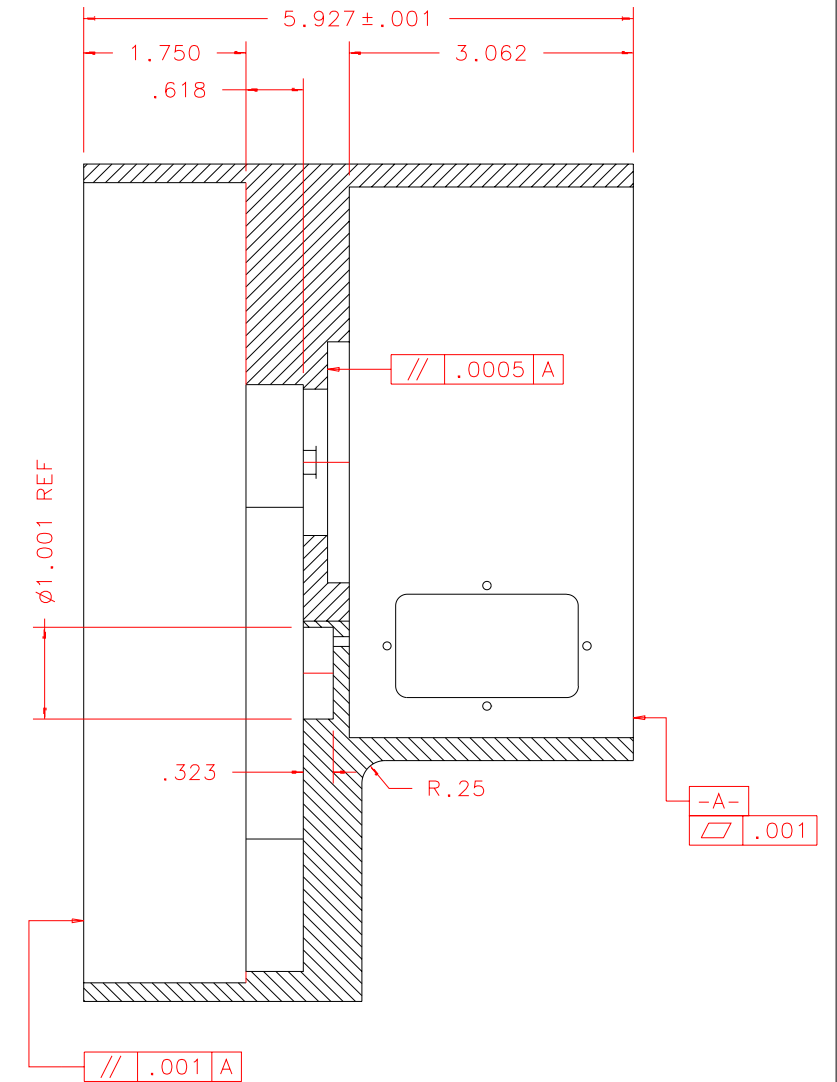

SECTION A-A: SCALE 1:2

REVDATE: 01/26/99	REVISION: ADD CON,POCKET SHEET 1 AND 8
REVDATE: 11-10/98	REVISION: ADD SHEET 8
REVDATE: 09/28/98	REVISION: ADD 8-32 AND C/B SHEET 4 RIGHT VIEW
REVDATE: 09/11/98	REVISION: ADD 2.000 DIM TOP VIEW + REF.DIMS
REVDATE: N/A	REVISION: N/A
DATE: 05/06/98	<b>INSTITUTE FOR ASTRONOMY</b>
DESIGN: STAHLBERGER	2680 WOODLAWN DR. HONOLULU, HI 96822
DRAWN: STAHLBERGER	INSTRUMENT: SPEX - CROSS DISPERSED SPECTROGRAPH
APPR'D: J. RAYNER	PART NAME: OPTICS BENCH
<b>TOLERANCES</b>	
X.X	+/- .015
X.XX	+/- .005
X.XXX	+/- .002
ANGLE	+/- 30 min
FRACTION	+/- 1/32
SG13-001B	DRW NO: SG13-016B
NEXT ASSY	SCALE: NOTED
	SIZE: B
	JOS NO: 725
	SHEET: 1 OF 8