

NOTES: UNLESS OTHERWISE NOTED
 1. MACHINED SURFACE ROUGHNESS 64
 O-RING GROOVES AND SURFACES 32
 2. REMOVE ALL BURRS/SHARP CORNERS

BILL OF MATERIAL				
NO.	REQ'D	REF DRW	DESCRIPTION	MATERIAL
N/A	1	SG13-019B	OPTICS BENCH SUPPORT	ALU 6061-T6

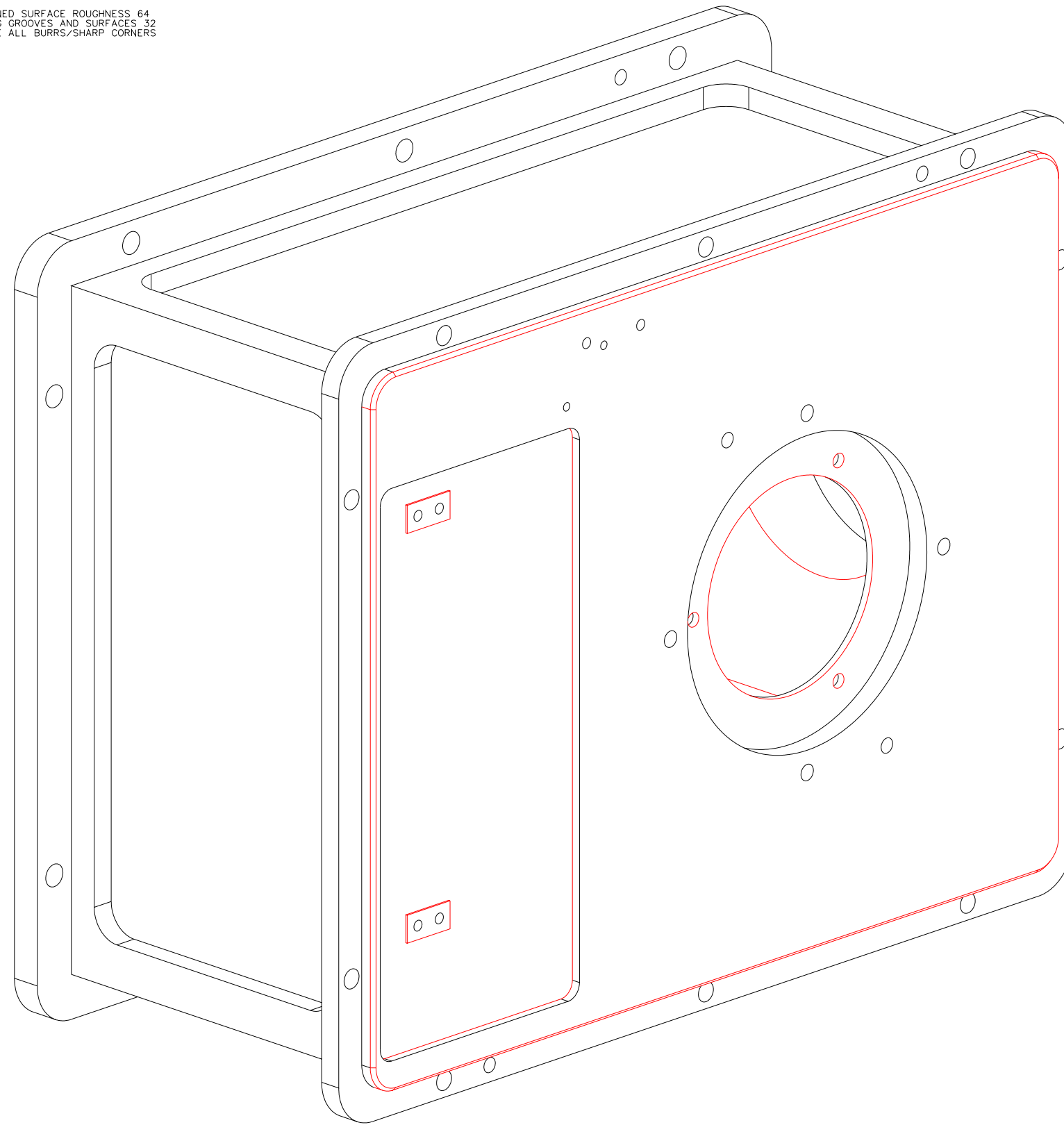

ISOVIEW 6: SCALE FULL

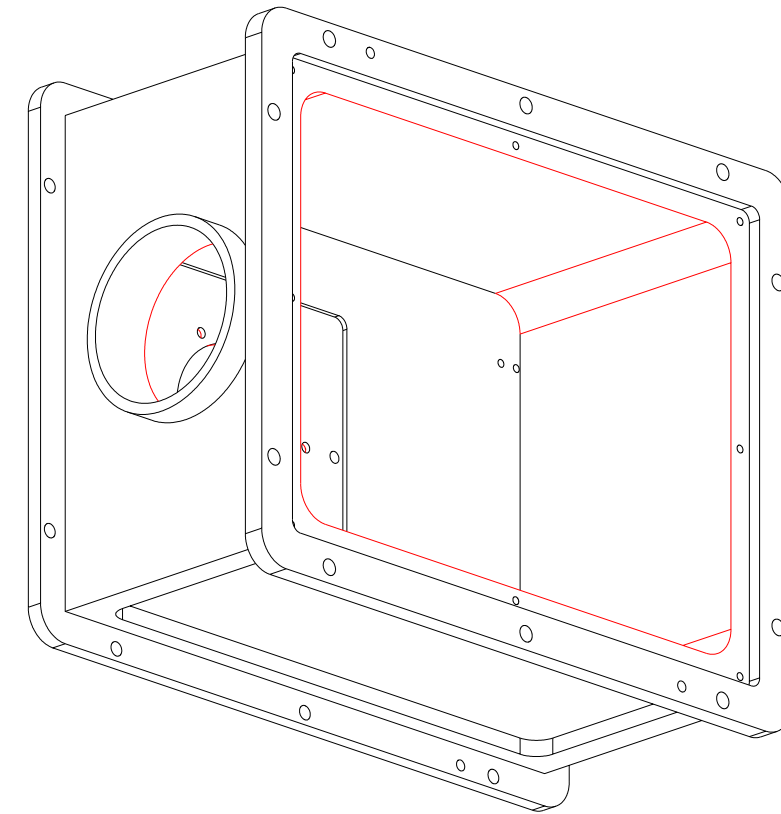

ISOVIEW 7: SCALE 1:2

PLOT: 10/19/99

SG13-001B
 NEXT ASSY

REVDATE: 01/26/99	REVISION: ADD 2x 2-56 HLS & CHAMFER SHEET1
REVDATE: 09/14/98	REVISION: ADD 4X R.125 SHEET4
REVDATE: N/A	REVISION: N/A
DATE: 05/07/98	INSTITUTE FOR ASTRONOMY
DESIGN: STAHLBERGER	2680 WOODLAWN DR. HONOLULU, HI 96822
DRAWN: STAHLBERGER	INSTRUMENT: SPEX - CROSS DISPERSED SPECTROGRAPH
APPR'D: J. RAYNER	PART NAME: OPTICS BENCH SUPPORT
TOLERANCES	TELESCOPE: IRTF
X.X +/- .015	DRW NO: SG13-019B
X.XX +/- .005	SCALE: NOTED
X.XXX +/- .002	SIZE: B
ANGLE +/- 30 min	JOS NO: 725
FRACTION +/- 1/32	SHEET: 5 OF 6