

NOTES: UNLESS OTHERWISE NOTED  
 1. MACHINED SURFACE ROUGHNESS 64  
 O-RING GROOVES AND SURFACES 32  
 2. REMOVE ALL BURRS/SHARP CORNERS

| BILL OF MATERIAL |       |          |                    |          |
|------------------|-------|----------|--------------------|----------|
| NO.              | REQ'D | REF DRW  | DESCRIPTION        | MATERIAL |
| N/A              | 1     | SJ0-001B | SLIT               | N/A      |
| 1                | 1     | SJ1-001A | DETENT (ASSEMBLY)  | N/A      |
| 2                | 1     | SJ2-001A | DRIVE (ASSEMBLY)   | N/A      |
| 3                | 1     | SJ3-001B | HOUSING (ASSEMBLY) | N/A      |
| 4                | 1     | SJ4-001B | WHEEL (ASSEMBLY)   | N/A      |

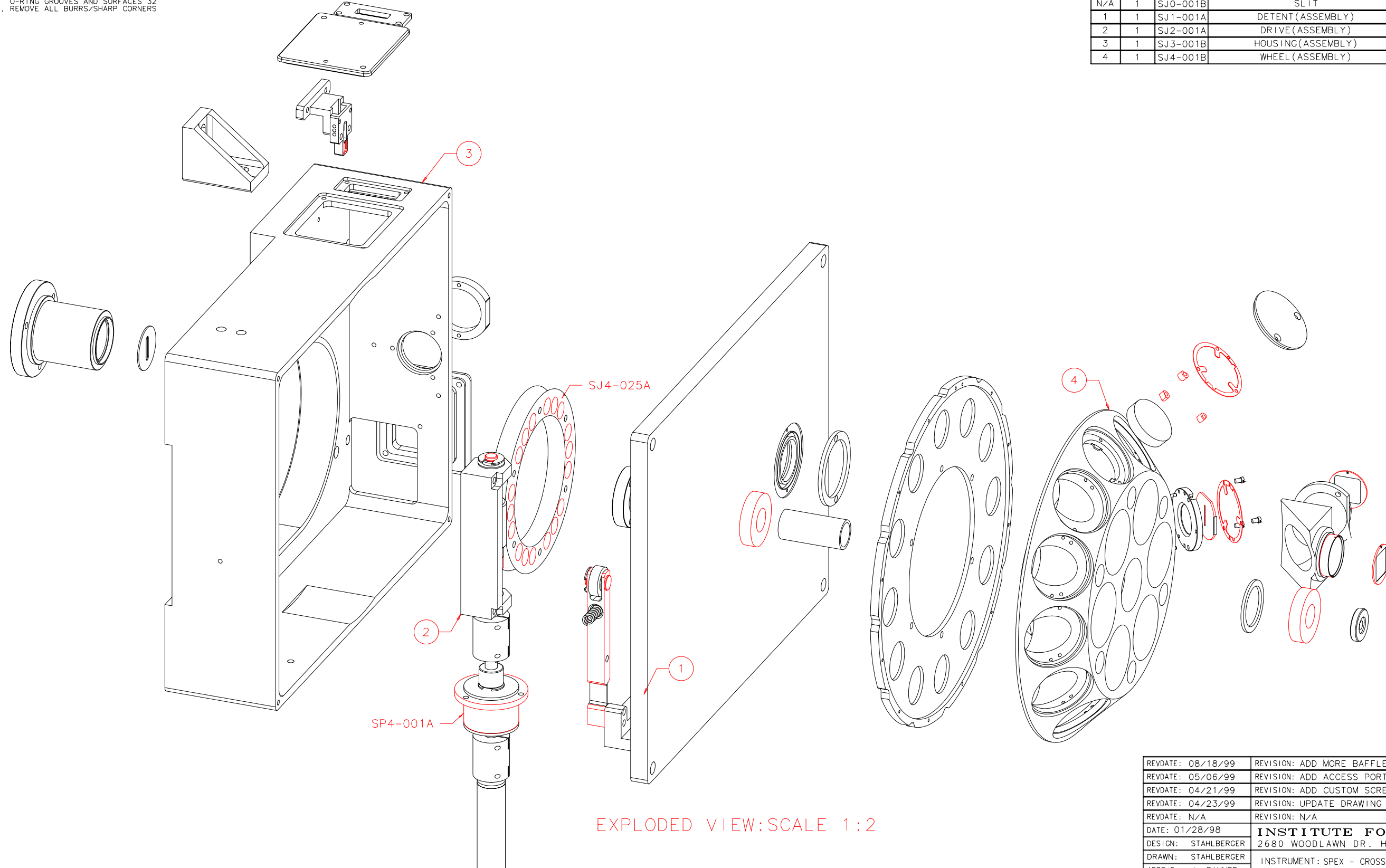

EXPLODED VIEW: SCALE 1:2

|                     |   |
|---------------------|---|
| REVDATE: 08/18/99   | REVISION: ADD MORE BAFFLES                      |
| REVDATE: 05/06/99   | REVISION: ADD ACCESS PORT +COVER                |
| REVDATE: 04/21/99   | REVISION: ADD CUSTOM SCREW TO SLIT MODULE       |
| REVDATE: 04/23/99   | REVISION: UPDATE DRAWING                        |
| REVDATE: N/A        | REVISION: N/A                                   |
| DATE: 01/28/98      | <b>INSTITUTE FOR ASTRONOMY</b>                  |
| DESIGN: STAHLBERGER | 2680 WOODLAWN DR. HONOLULU, HI 96822            |
| DRAWN: STAHLBERGER  | INSTRUMENT: SPEX - CROSS DISPERSED SPECTROGRAPH |
| APPR'D: J. RAYNER   | PART NAME: SLIT                                 |
| <b>TOLERANCES</b>   | TELESCOPE: IRTF                                 |
| X.X +/- .015        |   |
| X.XX +/- .005       |   |
| X.XXX +/- .002      |   |
| ANGLE +/- 30 min    |   |
| FRACTION +/- 1/32   |   |
| S00-001B            | DRW NO: SJ0-001B                                |
| NEXT ASSY           | SCALE: 1:2                                      |
|                     | SIZE: B   |
|                     | JOS NO: 725                                     |
|                     | SHEET: 3 OF 3                                   |

PLOT: 10/19/99