

NOTES: UNLESS OTHERWISE NOTED
 1. MACHINED SURFACE ROUGHNESS 64
 O-RING GROOVES AND SURFACES 32
 2. REMOVE ALL BURRS/SHARP CORNERS

BILL OF MATERIAL				
NO.	REQ'D	REF DRW	DESCRIPTION	MATERIAL
N/A	1	SJ3-013B	HOUSING	ALU 6061-T6

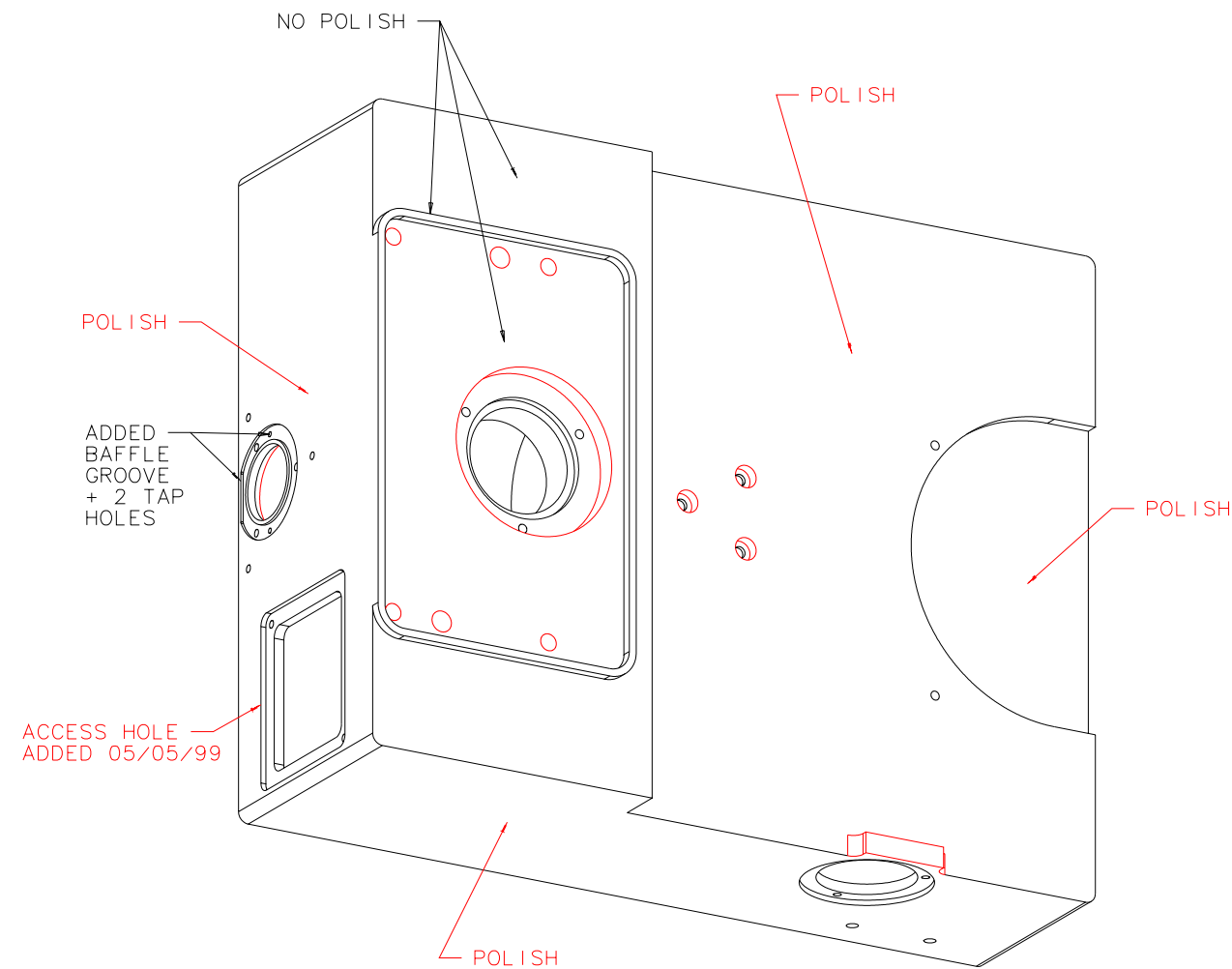

ISOVIEW 3: SCALE 1:2

POLISH INDICATED SURFACES TO A 10 MICRON FINISH

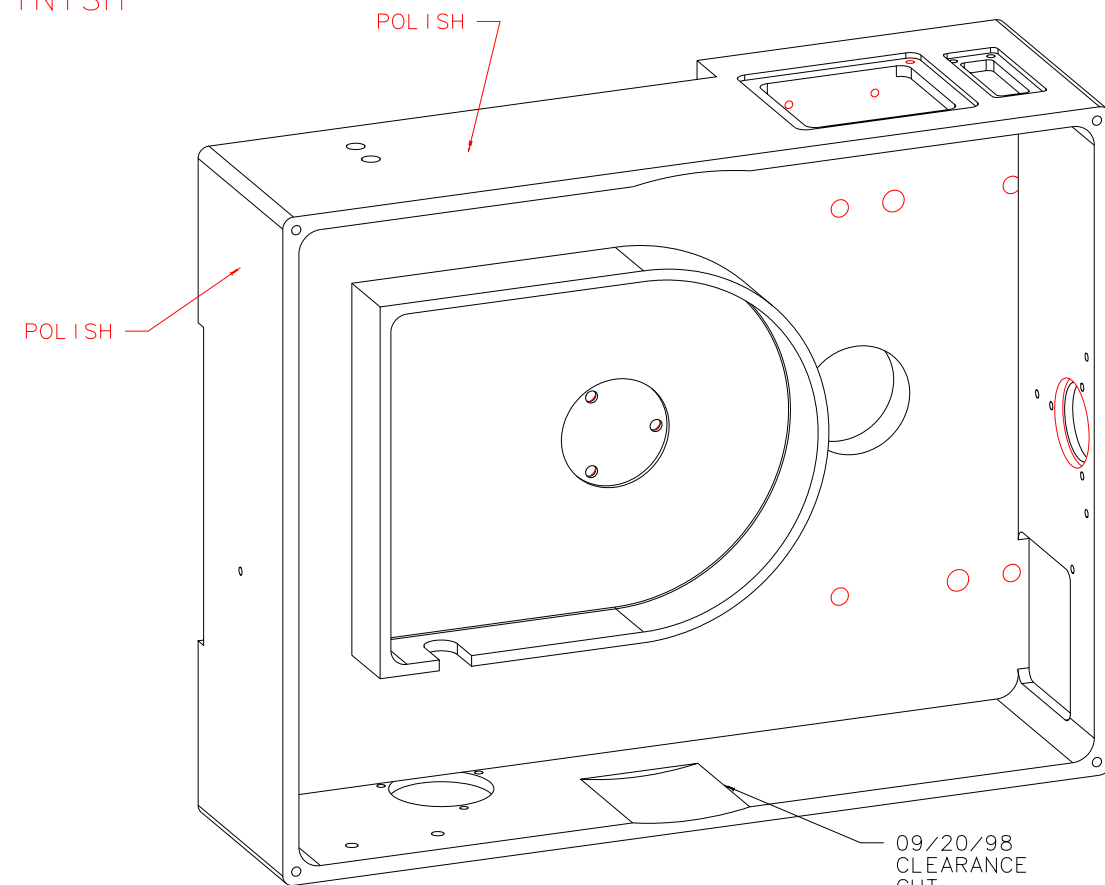

ISOVIEW 2: SCALE 1:2

REVDATE: 08/18/99	REVISION: BAFFLE GROOVE SHT1 RIGHT
REVDATE: 05/05/99	REVISION: ADD DETAIL D. SHEET 2
REVDATE: 04/22/99	REVISION: ADD .094 DIM SHEET2 SECT A-A
REVDATE: 04/15/99	REVISION: ADD MISSING DIM 3.533 SHEET 1 FRONT
REVDATE: 09/20/98	REVISION: ADD 2 CLEARANCE CUTS SHEET 1 AND 4
REVDATE: 09/20/98	REVISION: ADD 1X 4-40 TAPPED HOLE, LEFT VIEW
REVDATE: N/A	REVISION: N/A
DATE: 11/20/97	INSTITUTE FOR ASTRONOMY
DESIGN: STAHLBERGER	2680 WOODLAWN DR. HONOLULU, HI 96822
DRAWN: STAHLBERGER	INSTRUMENT: SPEX - CROSS DISPERSED SPECTROGRAPH
APPR'D: J. RAYNER	PART NAME: HOUSING
TOLERANCES	
X.X	+/- .015
X.XX	+/- .005
X.XXX	+/- .002
ANGLE	+/- 30 min
FRACTION	+/- 1/32
DRW NO: SJ3-013B	SCALE: 1:2
SIZE: B	JOS NO: 725
	SHEET: 4 OF 4

SJ3-001B	NEXT ASSY
----------	-----------

PLOT: 10/19/99