

NOTES: UNLESS OTHERWISE NOTED

1. MACHINED SURFACE ROUGHNESS 64
O-RING GROOVES AND SURFACES 32
2. REMOVE ALL BURRS/SHARP CORNERS

BILL OF MATERIAL				
NO.	REQ'D	REF DRW	DESCRIPTION	MATERIAL
N/A	1	SJ4-014A	ENTRANCE BAFFLE	ALU 6061-T6

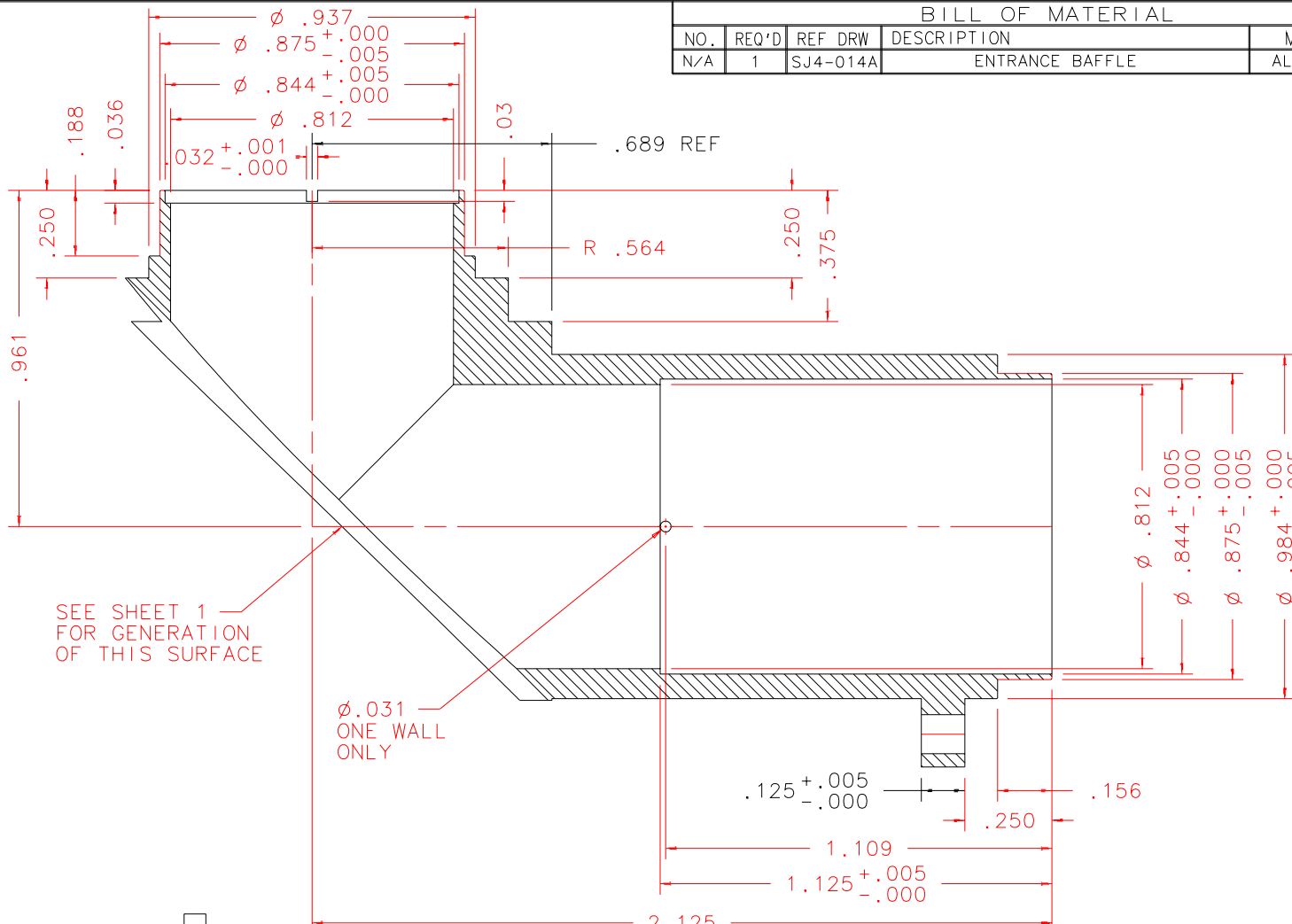

SECTION A-A: SCALE 2:1

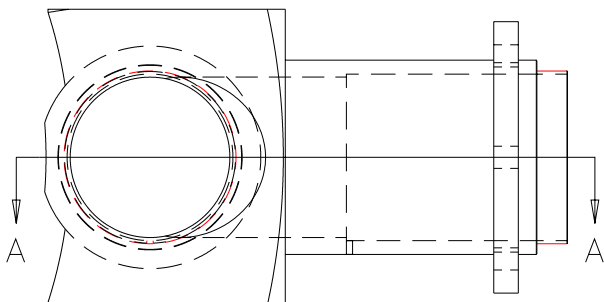

TOP: SCALE FULL

REVDATE: 04/09/99	REVISION: DIM .961 WAS .958
REVDATE: 04/03/99	REVISION: DIM .689 WAS R.689
REVDATE: 04/07/98	REVISION: ADD SLOT AND 1/32 HOLE
REVDATE: N/A	REVISION: N/A
DATE: 11/24/97	INSTITUTE FOR ASTRONOMY 2680 WOODLAWN DR. HONOLULU, HI 96822
DESIGN: STAHLBERGER	
DRAWN: STAHLBERGER	
APPR'D: J. RAYNER	
TOLERANCES	
X.X	+/- .015
X.XX	+/- .005
X.XXX	+/- .002
ANGLE	+/- 30 min
FRACTION	+/- 1/32
INSTRUMENT: SPEX - CROSS DISPERSED SPECTROGRAPH	
PART NAME: ENTRANCE BAFFLE	
TELESCOPE: IRTF	
DRW NO: SJ4-014A	SCALE: NOTED
SIZE: A	JOS NO: 725
SHEET: 2 OF 3	

PLOT: 10/19/99

SJ3-001B
NEXT ASSY