

NOTES: UNLESS OTHERWISE NOTED

1. MACHINED SURFACE ROUGHNESS 64
O-RING GROOVES AND SURFACES 32
2. REMOVE ALL BURRS/SHARP CORNERS

BILL OF MATERIAL

NO.	REQ'D	REF DRW	DESCRIPTION	MATERIAL
N/A	1	SJ4-019A	PRESSURE PAD	ALU 6061-T6

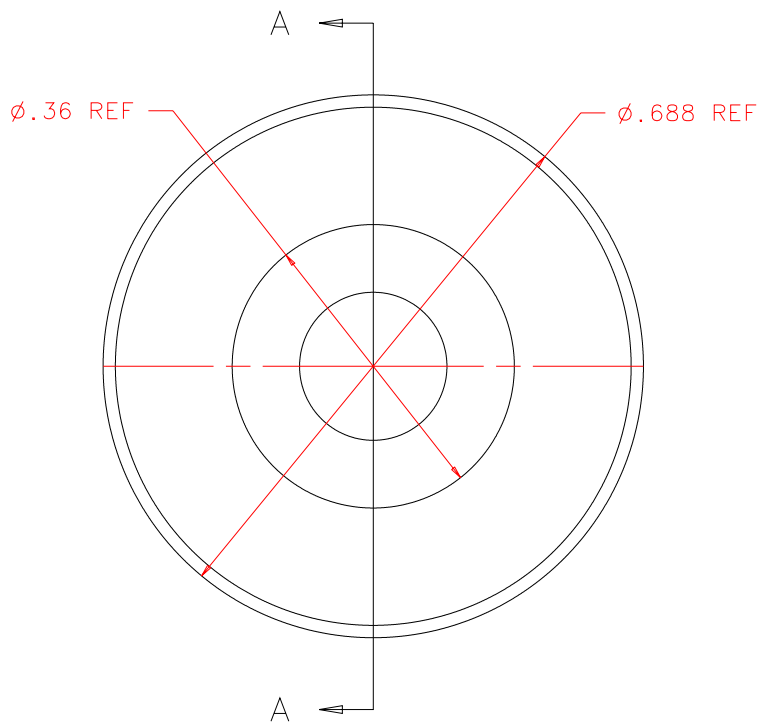

FRONT

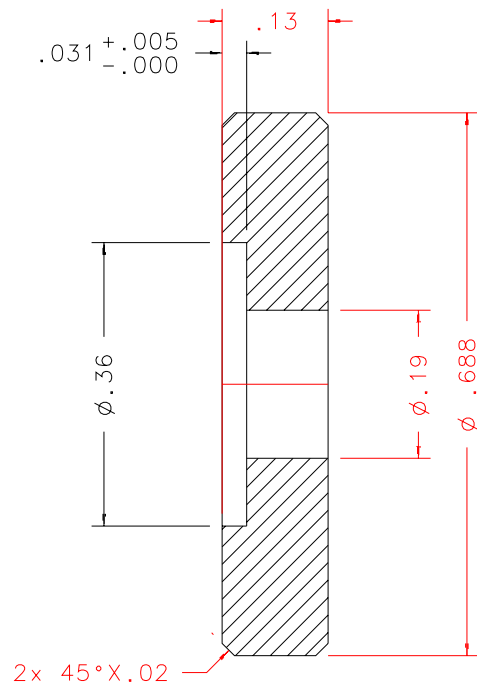

SECTION A-A

REVDATE: 05/14/99	REVISION: ADD COUNTERBORE
REVDATE: N/A	REVISION: N/A
DATE: 11/26/97	INSTITUTE FOR ASTRONOMY 2680 WOODLAWN DR. HONOLULU, HI 96822
DESIGN: STAHLBERGER	
DRAWN: STAHLBERGER	
APPR'D: J. RAYNER	
TOLERANCES	
X.X	+/- .015
X.XX	+/- .005
X.XXX	+/- .002
ANGLE	+/- 30 min
FRACTION	+/- 1/32
INSTRUMENT: SPEX - CROSS DISPERSED SPECTROGRAPH	
PART NAME: PRESSURE PAD	
TELESCOPE: IRTF	
DRW NO: SJ4-019A	SCALE: 4:1
SIZE: A	JOS NO: 725
SHEET: 1 OF 1	

PLOT: 10/19/99

SJ4-001B
NEXT ASSY