

NOTES: UNLESS OTHERWISE NOTED

1. MACHINED SURFACE ROUGHNESS 64  
O-RING GROOVES AND SURFACES 32
2. REMOVE ALL BURRS/SHARP CORNERS

BILL OF MATERIAL				
NO.	REQ'D	REF DRW	DESCRIPTION	MATERIAL
N/A	2	SN3-023A	STOPPING PIN	STAINLESS 303

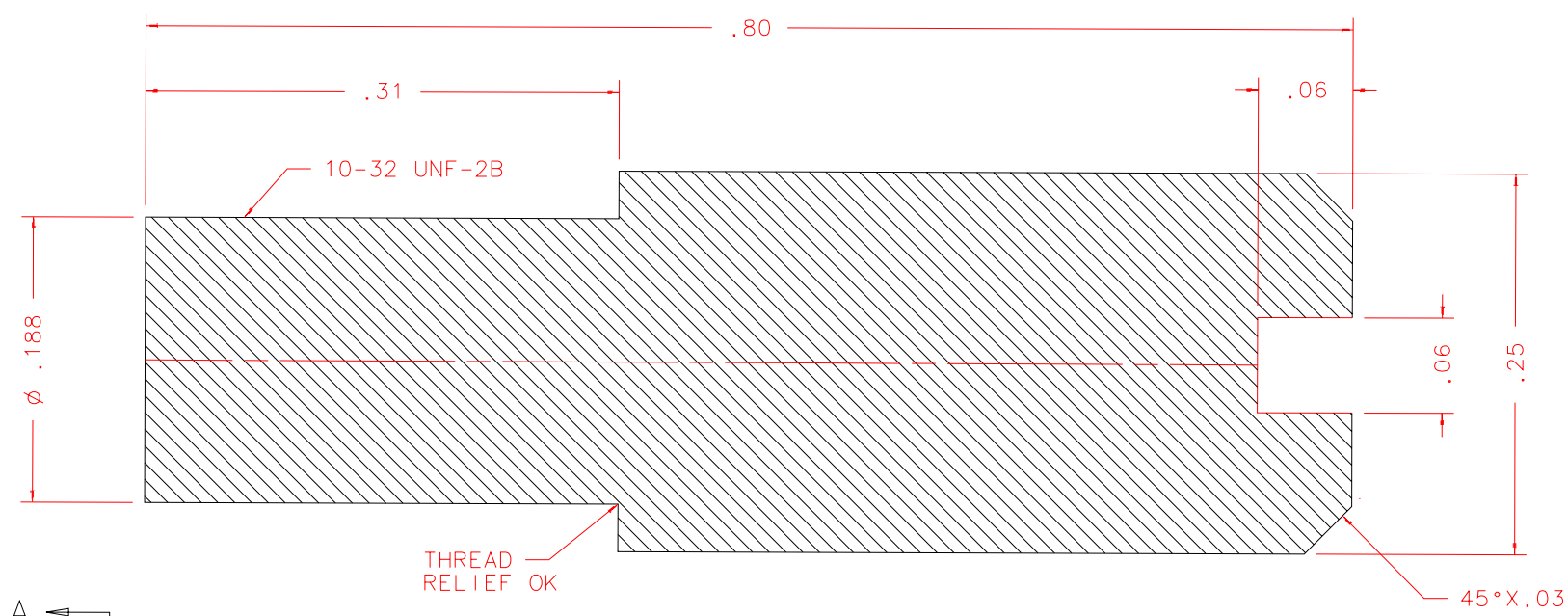

SECTION A-A

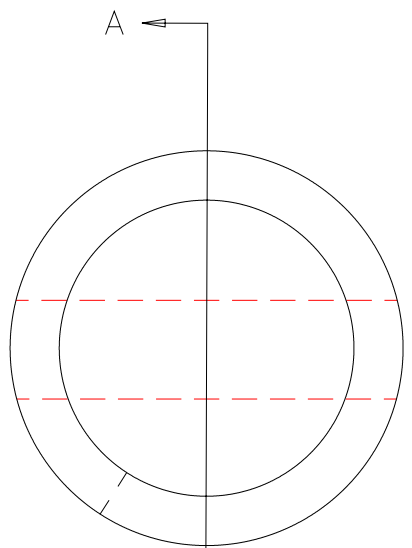

PLOT: 10/19/99

SN3-001B  
NEXT ASSY

REVDATE: N/A	REVISION: N/A
DATE: 11/08/97	<b>INSTITUTE FOR ASTRONOMY</b> 2680 WOODLAWN DR. HONOLULU, HI 96822
DESIGN: STAHLBERGER	
DRAWN: STAHLBERGER	
APPR'D: J. RAYNER	
<b>TOLERANCES</b>	
X.X	+/- .015
X.XX	+/- .005
X.XXX	+/- .002
ANGLE	+/- 30 min
FRACTION	+/- 1/32
INSTRUMENT: SPEX - CROSS DISPERSED SPECTROGRAPH	
PART NAME: STOPPING PIN	
TELESCOPE: IRTF	
DRW NO: SN3-023A	SCALE: 8:1
SIZE: A	JOS NO: 725
SHEET: 1 OF 1	