

NOTES: UNLESS OTHERWISE NOTED

1. MACHINED SURFACE ROUGHNESS 64
O-RING GROOVES AND SURFACES 32
2. REMOVE ALL BURRS/SHARP CORNERS

BILL OF MATERIAL

NO.	REQ'D	REF DRW	DESCRIPTION	MATERIAL
N/A	1	SN4-012A	AXIAL SPRING TRIPLET	PHOS. BRONZE

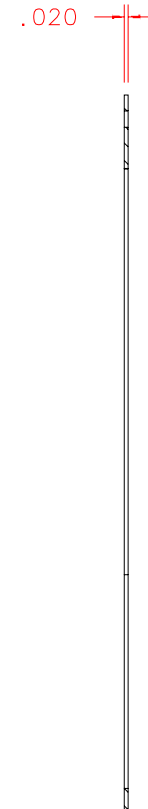
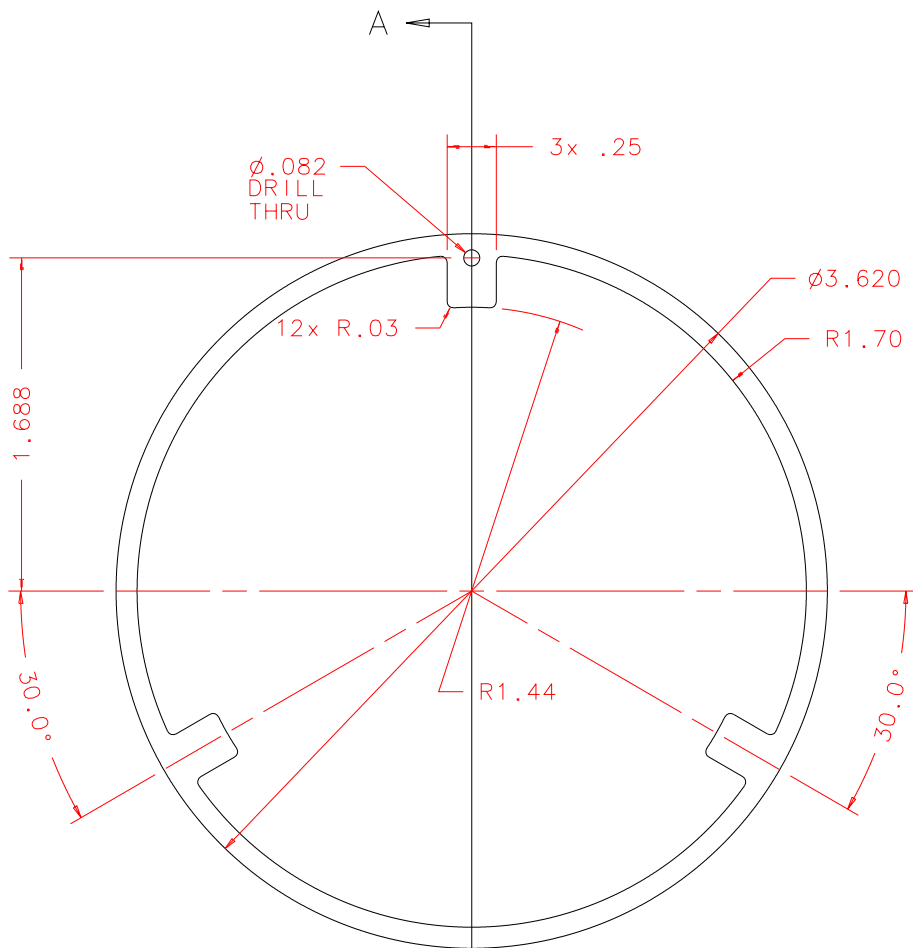

SECTION A-A

FRONT

REVDATE: N/A	REVISION: N/A
DATE: 11/14/97	INSTITUTE FOR ASTRONOMY 2680 WOODLAWN DR. HONOLULU, HI 96822
DESIGN: STAHLBERGER	
DRAWN: STAHLBERGER	INSTRUMENT: SPEX - CROSS DISPERSED SPECTROGRAPH PART NAME: AXIAL SPRING TRIPLET TELESCOPE: IRTF
APPR'D: J. RAYNER	
TOLERANCES	
X.X	+/- .015
X.XX	+/- .005
X.XXX	+/- .002
ANGLE	+/- 30 min
FRACTION	+/- 1/32
DRW NO: SN4-012A	SCALE: 1:1
SIZE: A	JOS NO: 725
SHEET: 1 OF 1	

PLOT: 10/19/99

SN4-001B
NEXT ASSY