

NOTES: UNLESS OTHERWISE NOTED
 1. MACHINED SURFACE ROUGHNESS 64
 O-RING GROOVES AND SURFACES 32
 2. REMOVE ALL BURRS/SHARP CORNERS

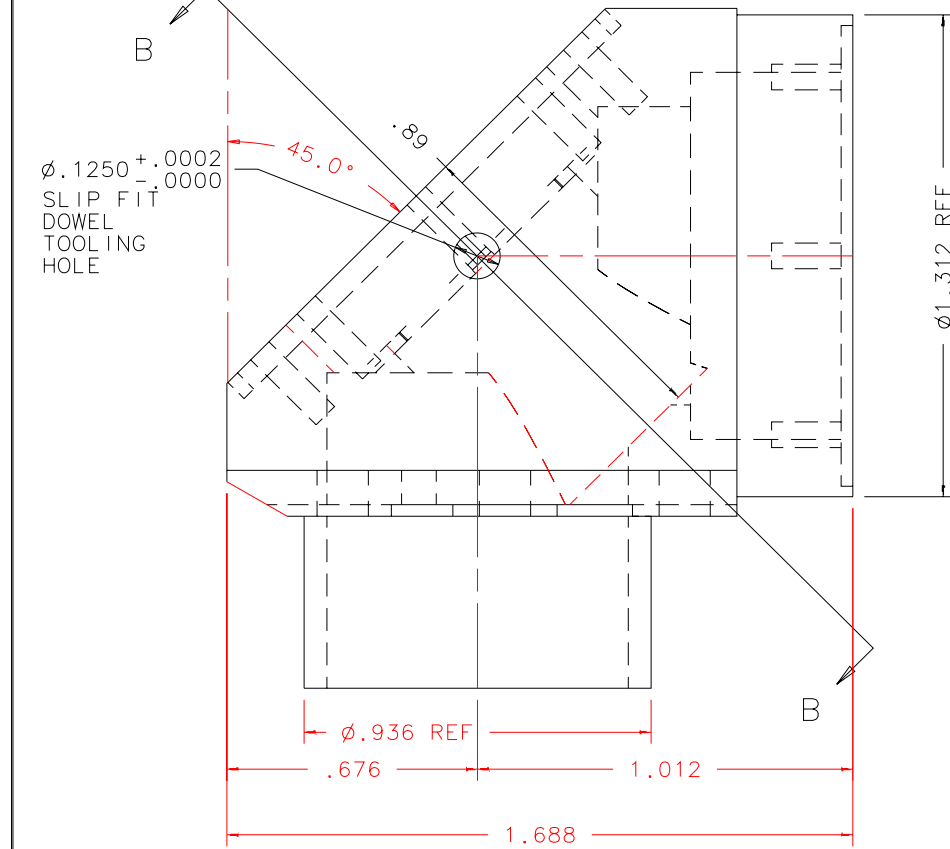

LEFT: SCALE 2:1

BILL OF MATERIAL				
NO.	REQ'D	REF	DESCRIPTION	MATERIAL
N/A	1	SN4-014B	FLATMOUNT NO7	ALU 6061-T6

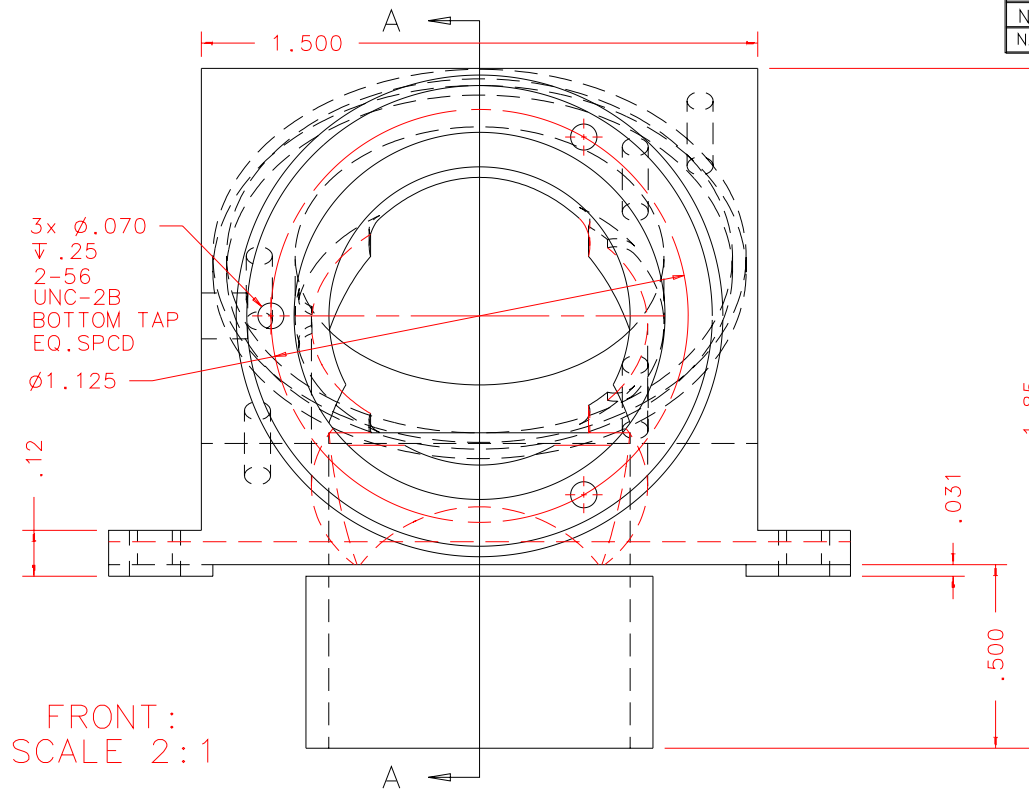

FRONT:
SCALE 2:1

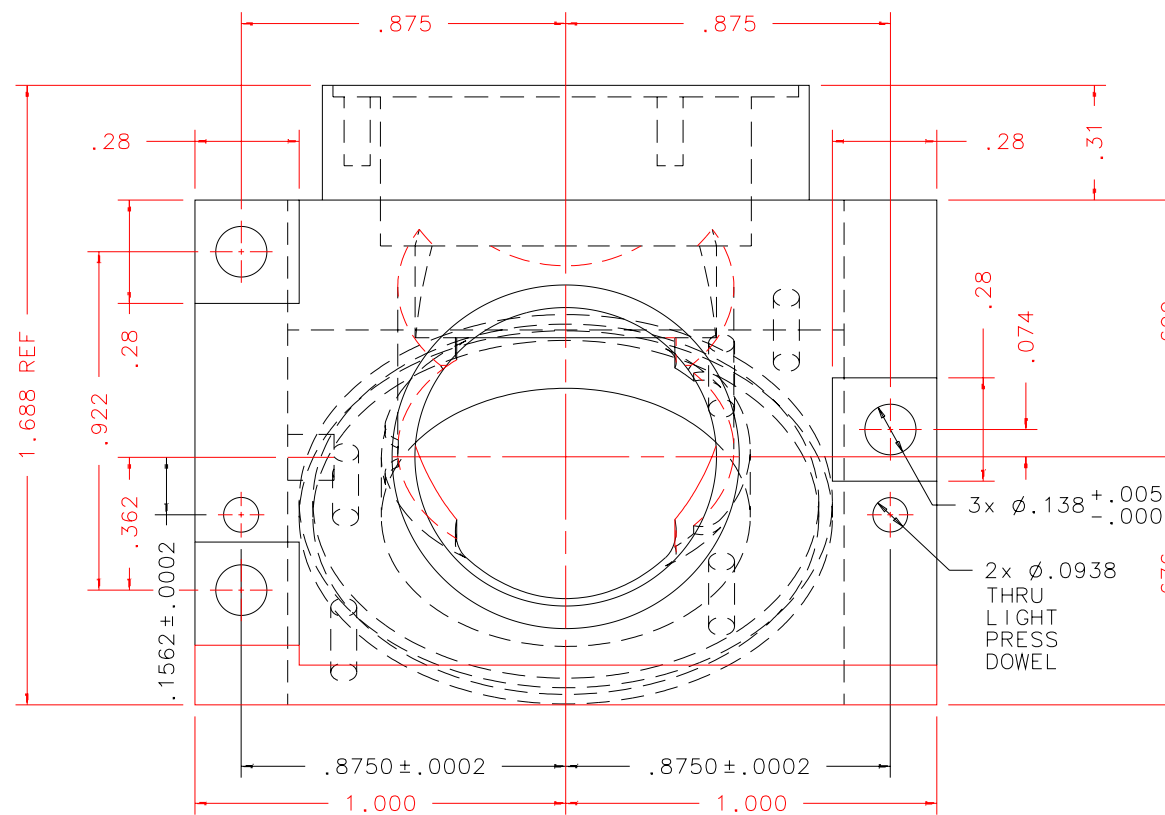

BOTTOM: SCALE 2:1

REVDATE: 06/04/99	REVISION: ADD 2x 3/32 DOWEL TOOLING HOLE
REVDATE: 04/05/99	REVISION: ADD DIM DIA.906 x .89 DEEP
REVDATE: 04/05/99	REVISION: ADD DIAMETER DIM 1.312 SECTION A-A
REVDATE: 04/02/99	REVISION: ADD CHAMFER .094 x 30°
REVDATE: 03/29/99	REVISION: ADD MISSING DIM 3x DIA.138
REVDATE: N/A	REVISION: N/A
DATE: 11/12/97	INSTITUTE FOR ASTRONOMY
DESIGN: STAHLBERGER	2680 WOODLAWN DR. HONOLULU, HI 96822
DRAWN: STAHLBERGER	INSTRUMENT: SPEX - CROSS DISPERSED SPECTROGRAPH
APPR'D: J. RAYNER	PART NAME: FLATMOUNT NO7
TOLERANCES	
X.X	+/- .015
X.XX	+/- .005
X.XXX	+/- .002
ANGLE	+/- 30 min
FRACTION	+/- 1/32
DRW NO: SN4-014B	SCALE: NOTED
SIZE: B	JOS NO: 725
SHEET: 1 OF 3	