

NOTES: UNLESS OTHERWISE NOTED

1. MACHINED SURFACE ROUGHNESS 64
O-RING GROOVES AND SURFACES 32
2. REMOVE ALL BURRS/SHARP CORNERS

BILL OF MATERIAL

NO.	REQ'D	REF DRW	DESCRIPTION	MATERIAL
N/A	1	SN5-035A	SQUARE BAFFLE NO2	ALU 6061-T6

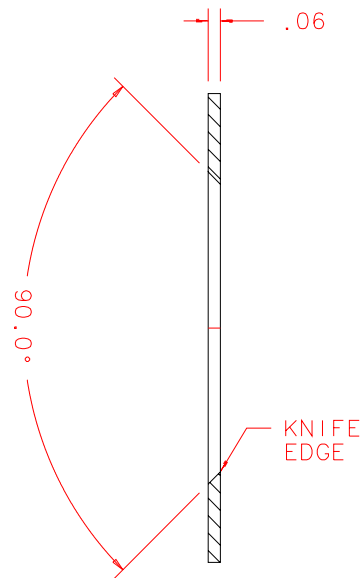
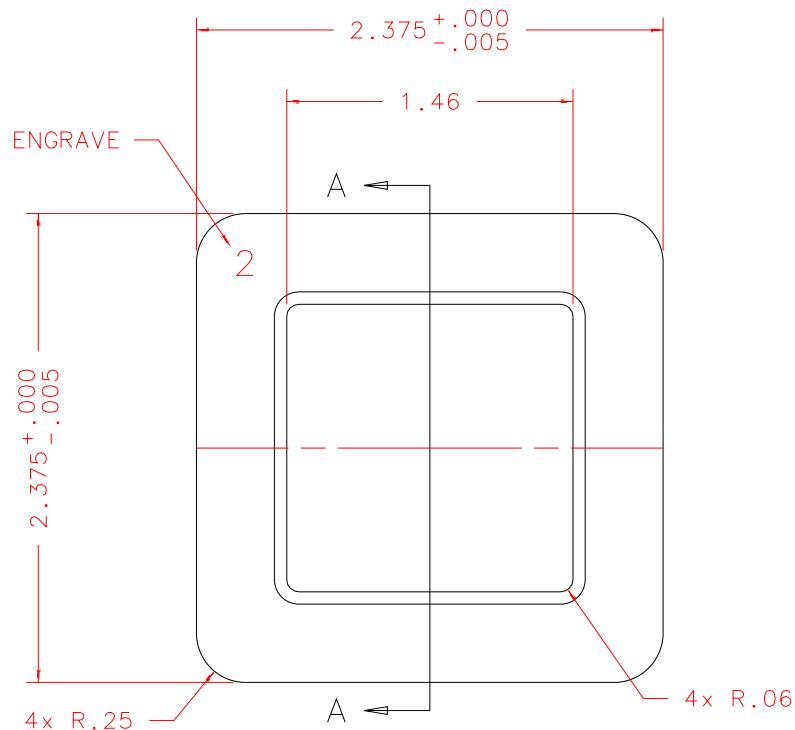

FRONT

SECTION A-A

PLOT: 10/19/99

SN5-001B
NEXT ASSY

REVDATE: N/A	REVISION: N/A
DATE: 11/18/97	INSTITUTE FOR ASTRONOMY
DESIGN: STAHLBERGER	2680 WOODLAWN DR. HONOLULU, HI 96822
DRAWN: STAHLBERGER	INSTRUMENT: SPEX - CROSS DISPERSED SPECTROGRAPH
APPR'D: J. RAYNER	PART NAME: SQUARE BAFFLE NO2
TOLERANCES	TELESCOPE: IRTF
X.X +/- .015	DRW NO: SN5-035A
X.XX +/- .005	SCALE: 1:1
X.XXX +/- .002	SIZE: A
ANGLE +/- 30 min	JOS NO: 725
FRACTION +/- 1/32	SHEET: 1 OF 1