

NOTES: UNLESS OTHERWISE NOTED

1. MACHINED SURFACE ROUGHNESS 64
O-RING GROOVES AND SURFACES 32
2. REMOVE ALL BURRS/SHARP CORNERS

BILL OF MATERIAL				
NO.	REQ'D	REF DRW	DESCRIPTION	MATERIAL
N/A	1	SN5-046A	TURRET BULKHEAD BAFFLE	ALU 6061-T6

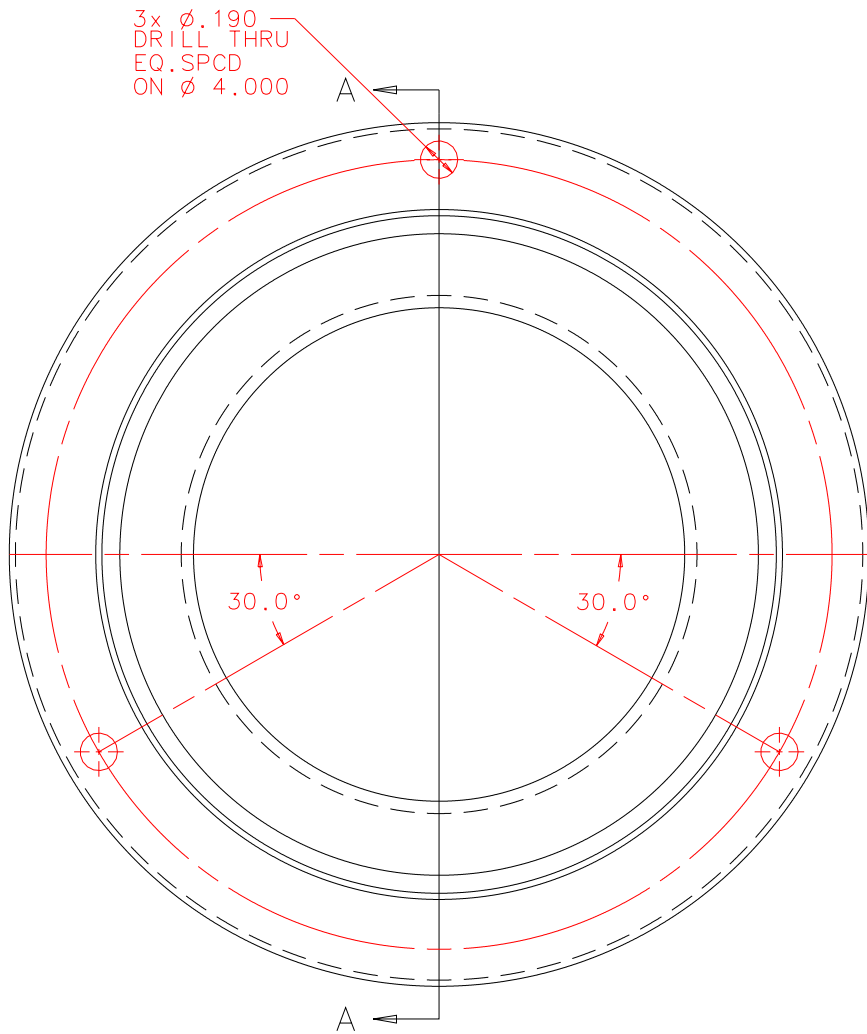

FRONT

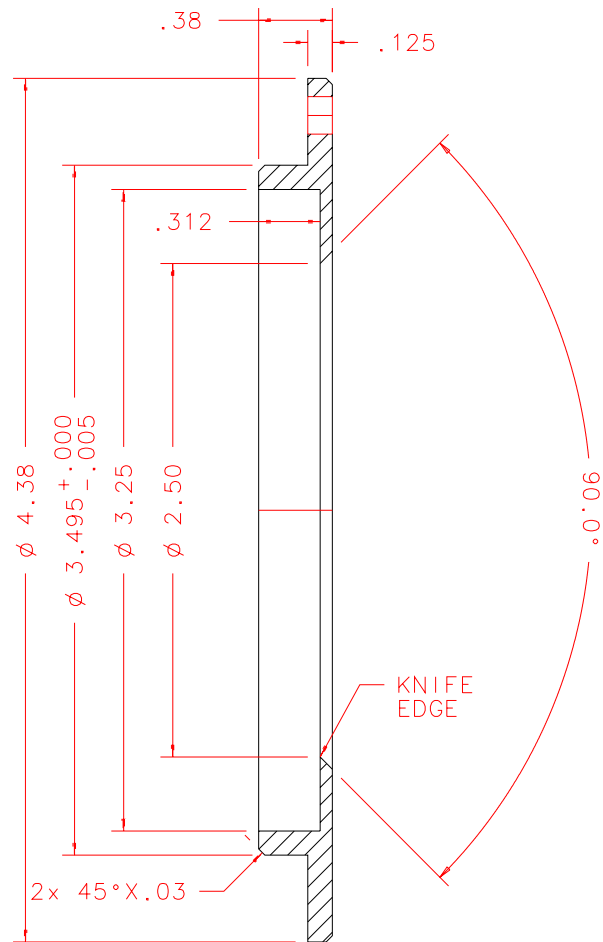

SECTION A-A

PLOT: 10/19/99

SN5-001B
NEXT ASSY

REVDATE: N/A	REVISION: N/A	
DATE: 11/18/97	INSTITUTE FOR ASTRONOMY 2680 WOODLAWN DR. HONOLULU, HI 96822	
DESIGN: STAHLBERGER		
DRAWN: STAHLBERGER		
APPR'D: J. RAYNER		
TOLERANCES		INSTRUMENT: SPEX - CROSS DISPERSED SPECTROGRAPH
X.X	+/- .015	PART NAME: TURRET BULKHEAD BAFFLE
X.XX	+/- .005	TELESCOPE: IRTF
X.XXX	+/- .002	DRW NO: SN5-046A
ANGLE	+/- 30 min	SCALE: 1:1
FRACTION	+/- 1/32	SIZE: A
		JOS NO: 725
		SHEET: 1 OF 1