

NOTES: UNLESS OTHERWISE NOTED

1. MACHINED SURFACE ROUGHNESS 64
O-RING GROOVES AND SURFACES 32
2. REMOVE ALL BURRS/SHARP CORNERS

BILL OF MATERIAL				
NO.	REQ'D	REF DRW	DESCRIPTION	MATERIAL
N/A	1	SN7-012A	FLEX STAGE MAGNET MOUNT	ALU 6061-T6

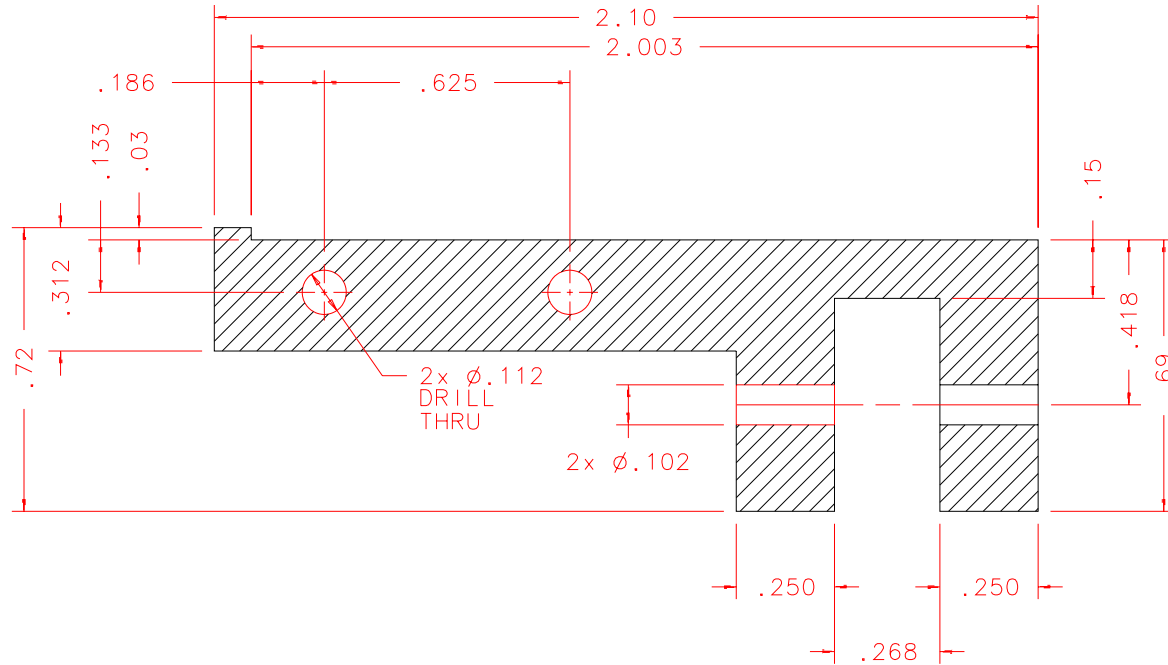

SECTION A-A: SCALE 2:1

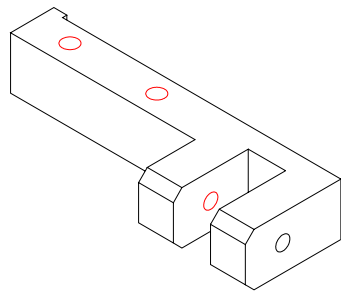

ISOVIEW 5: SCALE FULL

REVDATE: N/A	REVISION: N/A
DATE: 04/30/99	INSTITUTE FOR ASTRONOMY 2680 WOODLAWN DR. HONOLULU, HI 96822
DESIGN: STAHLBERGER	
DRAWN: STAHLBERGER	INSTRUMENT: SPEX - CROSS DISPERSED SPECTROGRAPH
APPR'D: J. RAYNER	PART NAME: FLEX STAGE MAGNET MOUNT
TOLERANCES	
X.X	+/- .015
X.XX	+/- .005
X.XXX	+/- .002
ANGLE	+/- 30 min
FRACTION	+/- 1/32
DRW NO: SN7-012A	SCALE: NOTED
SIZE: A	JOS NO: 725
SHEET: 2 OF 2	

SN7-001A
NEXT ASSY

PLOT: 10/19/99