

NOTES: UNLESS OTHERWISE NOTED
 1. MACHINED SURFACE ROUGHNESS 64
 O-RING GROOVES AND SURFACES 32
 2. REMOVE ALL BURRS/SHARP CORNERS

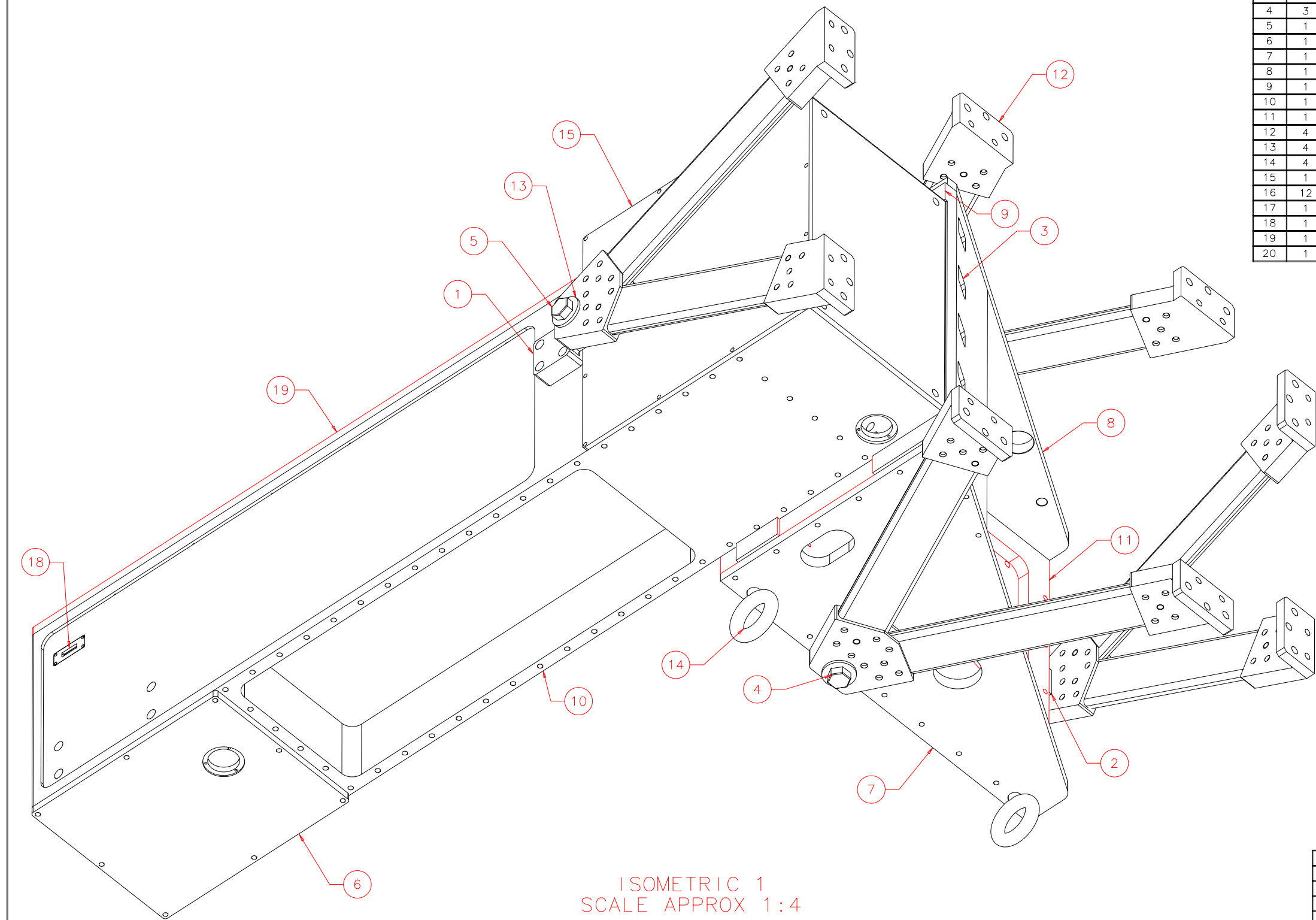

ISOMETRIC 1
 SCALE APPROX 1:4

BILL OF MATERIAL				
NO.	REQ'D	REF DRW	DESCRIPTION	MATERIAL
N/A	1	SEO-001B	SUPPORT TRUSS	N/A
1	1	SEO-011A	APEX PLATE +Y	STAINLESS 303
2	3	SEO-012A	APEX SPACER	ALU 6061-T6
3	1	SEO-013A	BRACE PLATE	ALU 6061-T6
4	3	SEO-014A	CUSTOM BOLT NO1	HIGH GRADE STL
5	1	SEO-015A	CUSTOM BOLT NO2	HIGH GRADE STL
6	1	SEO-022B	FOCUS DRIVE COVER	ALU 6061-T6
7	1	SEO-017B	GUSSET +X	ALU 6061-T6
8	1	SEO-018B	GUSSET -X	ALU 6061-T6
9	1	SEO-019B	GUSSET +Y	ALU 6061-T6
10	1	SEO-020B	SPECTROGRAPH BOX	ALU 6061-T6
11	1	SEO-021B	TRUSS MOUNT	ALU 6061-T6
12	4	SE1-001B	TRUSS LEG (ASSEMBLY)	N/A
13	4	N/A	WASHER 1/2	STAINLESS
14	4	N/A	EYE BOLT	STEEL
15	1	S30-026B	TURRET COVER PLATE	ALU 6061-T6
16	12	SEO-027A	EPOXY LIGHT PLUG	ALU 6061-T6
17	1	SEO-023A	QUAD34 MOUNT	ALU 6061-T6
18	1	SEO-024A	SINGLE30 MOUNT	ALU 6061-T6
19	1	SEO-025B	SPECTROCOVER -X	ALU 6061-T6
20	1	SEO-028A	SINGLE 30 MOUNT SUBPLATE	ALU 6061-T6

NOTE:
 A) SPECTROGRAPH BOX SEO-020B DESIGN NOT FINISHED. SUBSTITUTE WITH SPECTROBOX PLATE VERSION SE2-001B FOR CRYOTEST 1
 B) ITEMS SEO-024A, SEO-023A, SEO-027A NOT SHOWN
 C) 05/10/99 USE SEO-020B FOR ALL NEXT TESTS
 D) USE VENTED SCREW AS NEEDED

REVDATE: 05/10/99	REVISION: UPDATE DRAWING
REVDATE: N/A	REVISION: N/A
DATE: 03/19/97	INSTITUTE FOR ASTRONOMY
DESIGN: STAHLBERGER	2680 WOODLAWN DR. HONOLULU, HI 96822
DRAWN: STAHLBERGER	INSTRUMENT: SPEX - CROSS DISPERSED SPECTROGRAPH
APPR'D: J. RAYNER	PART NAME: SUPPORT TRUSS
TOLERANCES	
X.X	+/- .015
X.XX	+/- .005
X.XXX	+/- .002
ANGLE	+/- 30 min
FRACTION	+/- 1/32
DRW NO: SEO-001B	SCALE: NOTED
SIZE: B	JOS NO: 725
	SHEET: 1 OF 2