

NOTES: UNLESS OTHERWISE NOTED
 1. MACHINED SURFACE ROUGHNESS 64
 O-RING GROOVES AND SURFACES 32
 2. REMOVE ALL BURRS/SHARP CORNERS

POLISH EXTERIOR
 METAL SURFACES
 TO 10 MICRON FINISH

BILL OF MATERIAL					
NO.	REQ'D	REF DRW	DESCRIPTION	MATERIAL	
N/A	4	SE1-001B	TRUSS LEG	N/A	
1	4	SE1-011A	APEX SHOE	STAINLESS 303	
2	4	SE1-012A	SHOE LEFT	STAINLESS 303	
3	4	SE1-013A	SHOE RIGHT	STAINLESS 303	
4	4	SE1-014A	TRUSS LEG LEFT	G-10-CR	
5	4	SE1-015A	TRUSS LEG RIGHT	G-10-CR	
6	80	N/A	DOWEL PIN D28-6(BERG)	STAINLESS 416	

NOTE: TRUSS LEG WILL BE
 ASSEMBLED BY INSTITUTE
 FOR ASTRONOMY MACHINE
 SHOP

ASSEMBLY PROCEDURE:

- A) CHECK CLEARANCE BETWEEN TRUSS LEG AND SHOES, SHOULD BE .002-.005 INCH.
- B) CLEAN PARTS WITH ACETONE.
- C) MOUNT SHOES ON BASE & APEX DUPLICATING CONDITIONS IN VACUUM JACKET SETUP.
- D) EPOXY, USE ECCOBOND 286. CURE FOR 24 HRS.
- E) DRILL AND REAM FOR 1/4 DOWEL PIN.(PRESS FIT)
- F) INSERT DOWELS

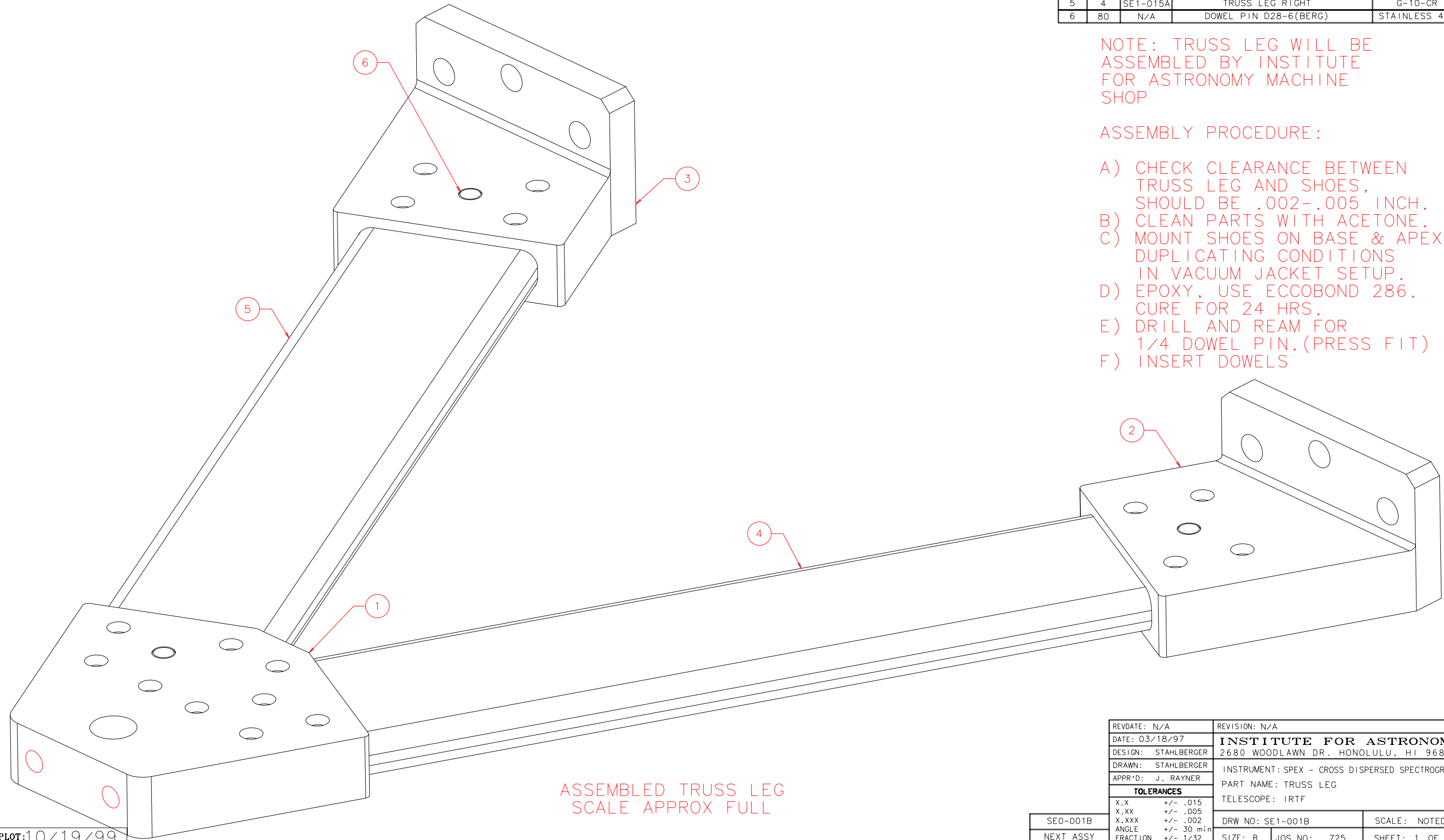

ASSEMBLED TRUSS LEG
 SCALE APPROX FULL

REVDATE: N/A	REVISION: N/A
DATE: 03/18/97	INSTITUTE FOR ASTRONOMY
DESIGN: STAHLBERGER	2680 WOODLAWN DR. HONOLULU, HI 96822
DRAWN: STAHLBERGER	INSTRUMENT: SPEX - CROSS DISPERSED SPECTROGRAPH
APPR'D: J. RAYNER	PART NAME: TRUSS LEG
TOLERANCES	
X.X	+/- .015
X.XX	+/- .005
X.XXX	+/- .002
ANGLE	+/- 30 min
FRACTION	+/- 1/32
DRW NO: SE1-001B	SCALE: NOTED
SIZE: B	JOS NO: 725
	SHEET: 1 OF 2

SE0-001B	NEXT ASSY
----------	-----------