

NOTES: UNLESS OTHERWISE NOTED

1. MACHINED SURFACE ROUGHNESS 64
O-RING GROOVES AND SURFACES 32
2. REMOVE ALL BURRS/SHARP CORNERS

BILL OF MATERIAL				
NO.	REQ'D	REF DRW	DESCRIPTION	MATERIAL
N/A	4	SE1-013A	SHOE RIGHT	STAINLESS 303

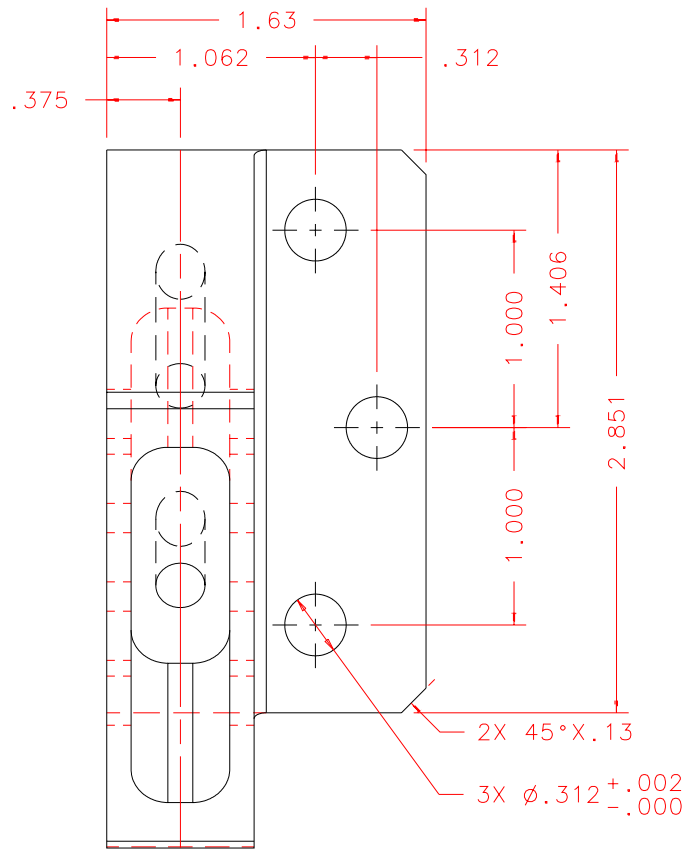

FRONT

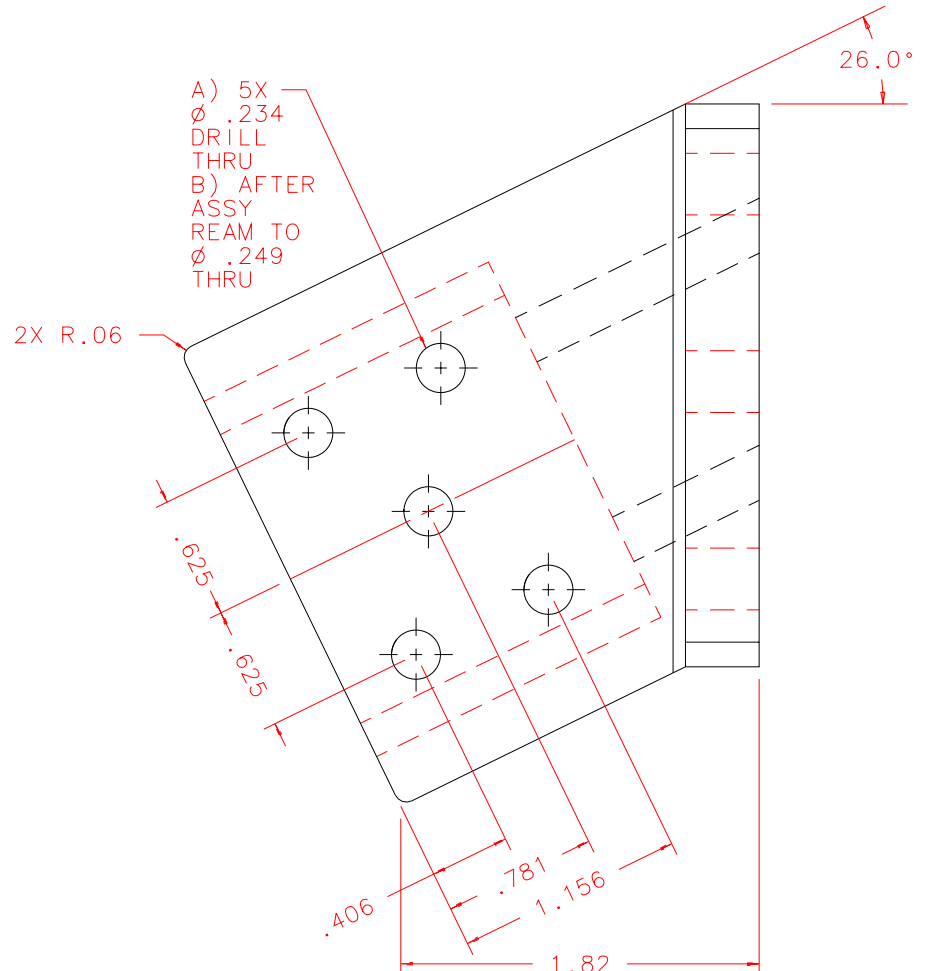

RIGHT

REVDATE: 04/21/98	REVISION: ADD 2 1/4 DIA EPOXY VENT HOLES
REVDATE: N/A	REVISION: N/A
DATE: 03/18/97	INSTITUTE FOR ASTRONOMY
DESIGN: STAHLBERGER	2680 WOODLAWN DR. HONOLULU, HI 96822
DRAWN: STAHLBERGER	INSTRUMENT: SPEX - CROSS DISPERSED SPECTROGRAPH
APPR'D: J. RAYNER	PART NAME: SHOE RIGHT
TOLERANCES	
X.X	+/- .015
X.XX	+/- .005
X.XXX	+/- .002
ANGLE	+/- 30 min
FRACTION	+/- 1/32
DRW NO: SE1-013A	SCALE: 1:1
SIZE: A	JOS NO: 725
SHEET: 1 OF 3	

PLOT:10/19/99

SE1-001B

NEXT ASSY