

NOTES: UNLESS OTHERWISE NOTED  
 1. MACHINED SURFACE ROUGHNESS 64  
 O-RING GROOVES AND SURFACES 32  
 2. REMOVE ALL BURRS/SHARP CORNERS

ISOVIEW 2  
 SCALE 3/16

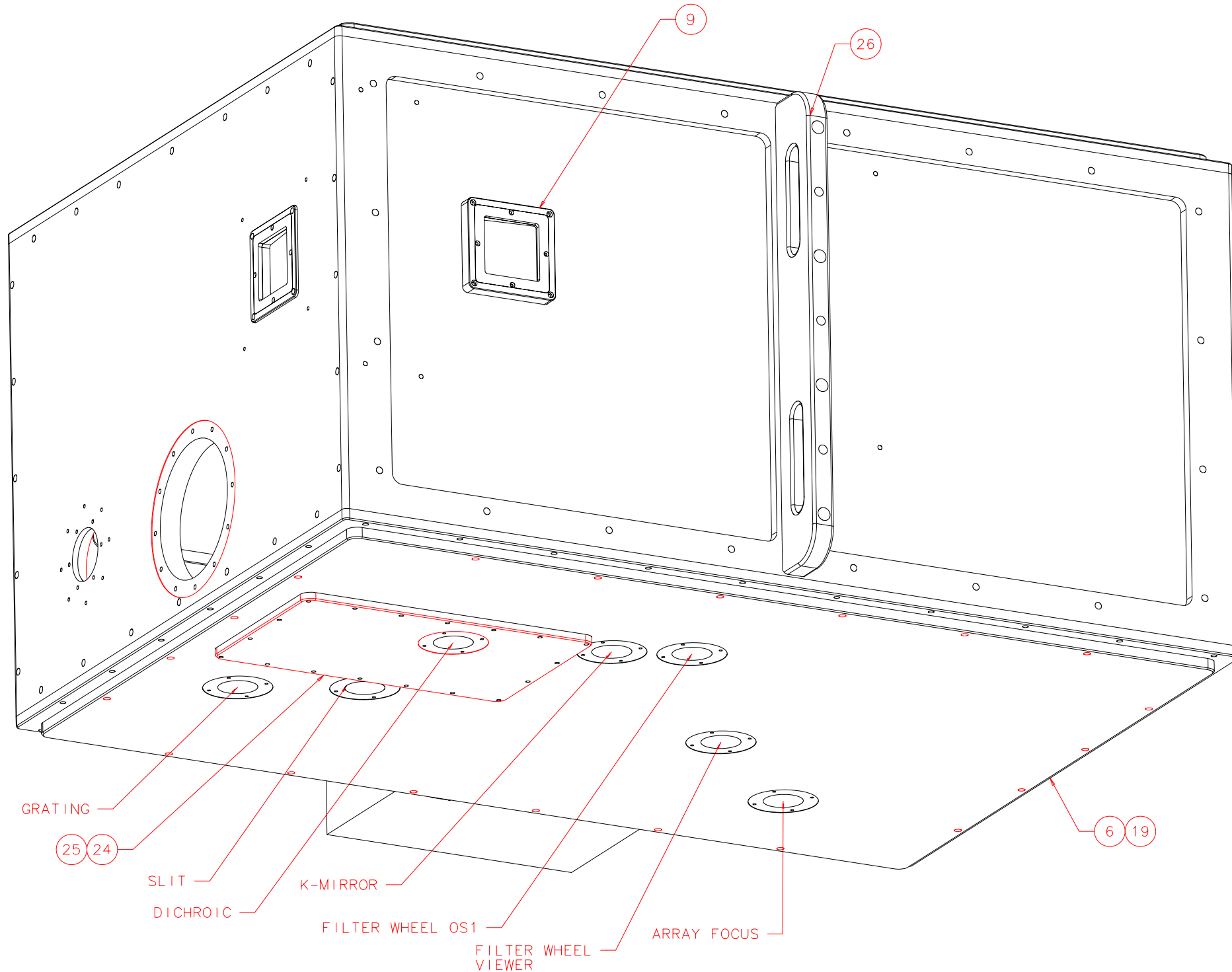

BILL OF MATERIAL				
NO.	REQ'D	REF DRW	DESCRIPTION	MATERIAL
N/A	1	SB0-001B	VACUUM JACKET	N/A
1	1	SB3-011B	CENTER SECTION	ALU 2219
2	8	SB3-012A	COVER HANDLE	ALU 6061-T6
3	6	SB3-013A	CONNECTOR PLATE 61 PIN	ALU 6061-T6
4	4	SB3-014A	CONNECTOR PLATE 55 PIN	ALU 6061-T6
5	1	SB3-015A	COVER GRATTURRET	ALU 6061-T6
6	1	SB3-016B	MOTOR COVER PLATE	ALU 6061-T6
7	1	SB3-017A	VALVE PORT COVER	ALU 6061-T6
8	1	SB3-018A	SPREADER BAR (NOT SHOWN)	ALU 6061-T6
9	2	SB1-001A	5DEG WINDOW(ASSEMBLY)	N/A
10	1	SL3-011a	FILL NECK FLANGE(NOT SHOWN)	ALU 6061-T6
11	1	SD5-011B	VACUUM JACKET ADAPTOR(NOT SHOWN)	ALU 6061-T6
12	1	N/A	VALVE SA-150-K-N (KEY)	STAINLESS
13	1	N/A	CENTERING RING KSCR-1740(KEY)	STAINLESS
14	1	N/A	BULKHEAD CLAMP 716002(MCD)	ALU
15	6	N/A	O-RING 2-042	BUNA-N
16	1	N/A	O-RING 2-134	BUNA-N
17	1	N/A	O-RING 2-278	BUNA-N
18	1	N/A	O-RING 2-165	BUNA-N
19	2	N/A	CUSTOM O-RING 45 ID X 3/16 W	BUNA-N
20	1	N/A	O-RING 2-136	BUNA-N
21	1	N/A	O-RING 2-142	BUNA-N
22	1	N/A	O-RING 2-152	BUNA-N
23	1	SB3-019B	COVER -X	ALU 6061-T6
24	1	SB3-020A	ACCESS PLATE CCC	ALU 6061-T6
25	1	N/A	O-RING 2-278	BUNA-N
26	2	SB3-021B	STIFFENING RIB	ALU 6061-T6

REVDATE: 10/15/99	REVISION: UPDATE DRAWING
REVDATE: 02/09/99	REVISION: UPDATE DRAWING
REVDATE: N/A	REVISION: N/A
DATE: 01/09/97	<b>INSTITUTE FOR ASTRONOMY</b>
DESIGN: STAHLBERGER	2680 WOODLAWN DR. HONOLULU, HI 96822
DRAWN: STAHLBERGER	INSTRUMENT: SPEX - CROSS DISPERSED SPECTROGRAPH
APPR'D: J. RAYNER	PART NAME: VACUUM JACKET
<b>TOLERANCES</b>	
X.X	+/- .015
X.XX	+/- .005
X.XXX	+/- .002
ANGLE	+/- 30 min
FRACTION	+/- 1/32
DRW NO: SB0-001B	SCALE: N/A
SIZE: B	JOS NO: 762
SHEET: 2 OF 2	

PLOT: 10/19/99

S00-001B	NEXT ASSY
----------	-----------