

NOTES: UNLESS OTHERWISE NOTED
 1. MACHINED SURFACE ROUGHNESS 64
 O-RING GROOVES AND SURFACES 32
 2. REMOVE ALL BURRS/SHARP CORNERS

BILL OF MATERIAL				
NO.	REQ'D	REF DRW	DESCRIPTION	MATERIAL
N/A	1	SB3-011B	CENTER SECTION	ALU 2219

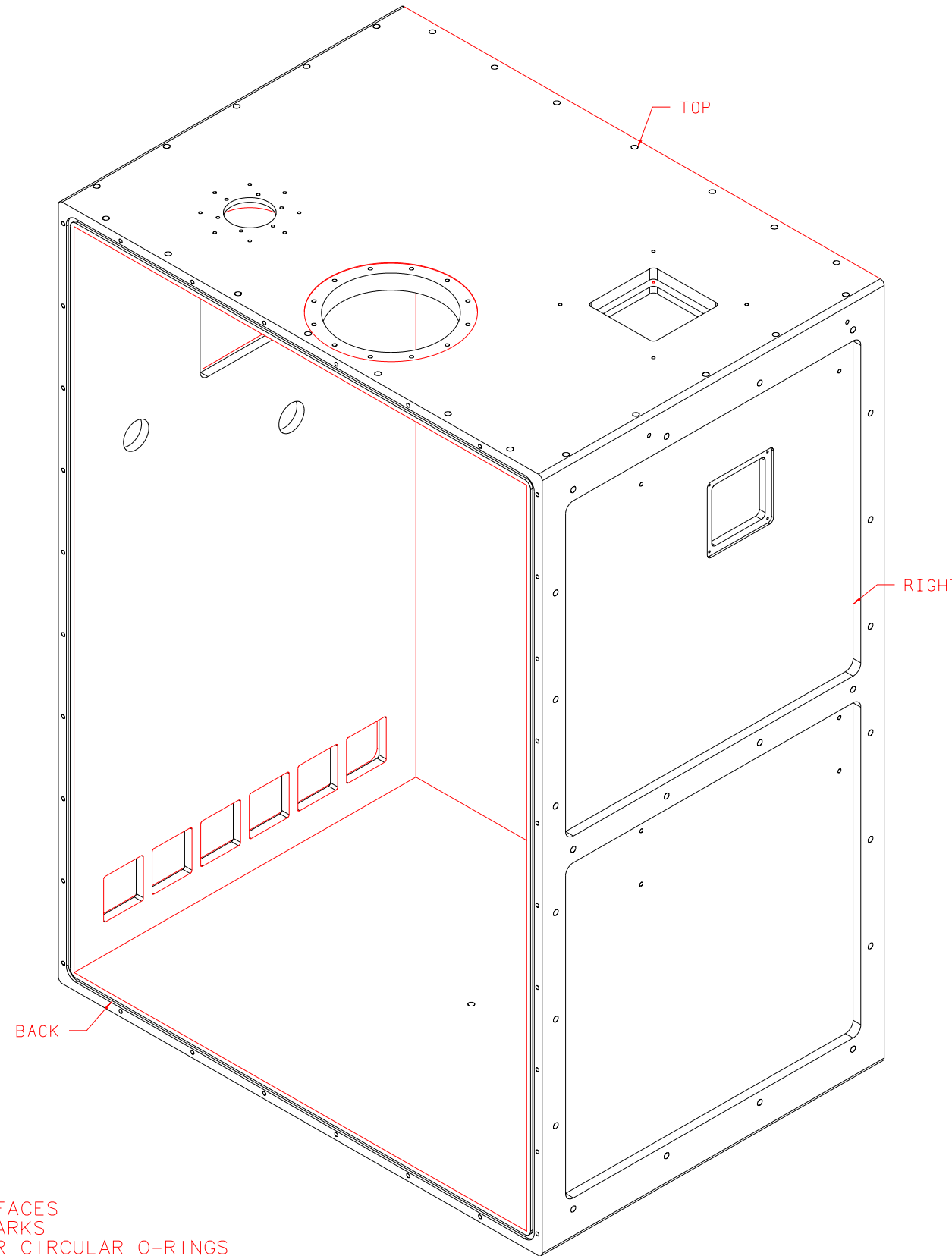

ANODIZE:
 COLOR: TBD
 MASK: ALL INSIDE
 LOOKING SURFACES

GENERAL NOTE ON O-RING SURFACES
 A) LEAVE NO VISIBLE TOOL MARKS
 B) USE SPOT FACE METHOD FOR CIRCULAR O-RINGS
 C) USE ONLY 600 GRIT PAPER FOR CLEANUP

PLOT: 10/19/99

SB0-001B	NEXT ASSY
----------	-----------

REVDATE: 08/03/99	REVISION: DET C: DIM 10.27 SQR WAS 10.00 SQR
REVDATE: N/A	REVISION: N/A
DATE: 12/26/96	INSTITUTE FOR ASTRONOMY
DESIGN: STAHLBERGER	2680 WOODLAWN DR. HONOLULU, HI 96822
DRAWN: STAHLBERGER	INSTRUMENT: SPEX - CROSS DISPERSED SPECTROGRAPH
APPR'D: J. RAYNER	PART NAME: CENTER SECTION
TOLERANCES	
X.X	+/- .015
X.XX	+/- .005
X.XXX	+/- .002
ANGLE	+/- 30 min
FRACTION	+/- 1/32
DRW NO: SB3-011B	SCALE: 1:4
SIZE: B	JOS NO: 762
	SHEET: 5 OF 6