

Title: Safety Board Analyses

Author: Eric Warmbier

Description: Any mathematical calculations for circuit design of the Safety Board are contained in this document. This document determined the design values and also serves as a guide (and reminder) as to why values for compenents were chosen. Keep in mind that the safety board resides in doors and that the temperature seen on the board will likely be around 25C or higher (due to localized component heating). Therefore, with low power components, a 0C to 50C temperature should be sufficient for analysis.

CPLD Clock - 555 timer circuit.

BACKGROUND: on board oscillator is very low frequency. A 555 timer works well for this application.

Directions

Fill in yellow highlighted regions.

Pink highlighted areas are results of interest.

Variables

clk_freq := 10Hz

Frequency of clock.

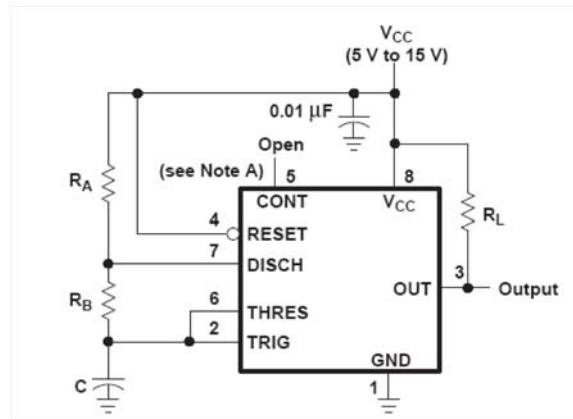

Analysis section

Pick a standard capacitor value to start.

C_555 := 10μF

Now the total value of (RA + 2RB) can be determined.

RA := 1kΩ

RB := 1kΩ

Required guess values.

Given

$$\text{clk_freq} = \frac{1.44}{(RA + 2 \cdot RB) \cdot C_{555}}$$

$$\text{total_R} := \text{Find}(RA + 2 \cdot RB) = 14.4 \cdot \text{k}\Omega$$

Select a value for RA:

$$RA_{\text{actual}} := 4.75\text{k}\Omega$$

$$RB_{\text{guess}} := 1\text{k}\Omega \quad \text{Required guess values.}$$

Given

$$RA_{\text{actual}} + 2 \cdot RB_{\text{guess}} = \text{total_R}$$

$$\text{Find}(RB_{\text{guess}}) = 4.825 \cdot \text{k}\Omega$$

Select an actual value for RB:

$$RB_{\text{actual}} := 4.75\text{k}\Omega$$

The final parameters are:

$$\text{frequency}_{555} := \frac{1.44}{(RA_{\text{actual}} + 2 \cdot RB_{\text{actual}}) \cdot C_{555}} = 10.105 \cdot \text{Hz}$$

$$\text{time}_{\text{high}} := 0.693 \cdot (RA_{\text{actual}} + RB_{\text{actual}}) \cdot C_{555} = 0.066 \text{ s}$$

$$\text{time}_{\text{low}} := 0.693 \cdot (RB_{\text{actual}}) \cdot C_{555} = 0.033 \text{ s}$$

$$\text{duty_cycle}_{\text{high}} := \frac{\text{time}_{\text{high}}}{(\text{time}_{\text{high}} + \text{time}_{\text{low}})} = 0.667$$

Optocoupler Circuit Driven by LM339s

BACKGROUND: the LM139 driving the optocoupler diode has a guaranteed minimum drive of 6 mA. So, for this analysis, use 5mA as the target.

Directions

Fill in **yellow highlighted** regions.

Pink highlighted areas are results of interest.

Variables

- LM239_I_sink_min := 6mA **LM239 min sink current.**
- LM239_VCE_sat := 0.4V **LM239 max sat voltage.**
- Power_supply_total := 30V **Power supply voltage (+/-15V = 30V).**
- Vf_diode_cold := 1.15V **Forward diode drop at 0C, IF=5mA.**
- Vf_diode_warm := 1.1V **Forward diode drop at 0C, IF=5mA.**
- CTR_min := 50% **CTR min at 5mA.**
- Logic_supply := 5V **Power supply voltage for logic side.**
- Dark_current := 0.01µA **Dark current at 60C.**
- Schmitt_logic_high_max := 3.6V **Schmitt trigger logic high input voltage and VCE=5V.**
- Schmitt_logic_low_max := 2.8V **Schmitt trigger logic low input voltage max.**
- Schmitt_logic_low_min := 0.9V **Schmitt trigger logic low input voltage min.**
- opto_VCE_sat_max := 0.4V **Collector-Emitter saturation voltage.**
- LP_freq_cutoff := 100Hz **Filter cutoff frequency.**

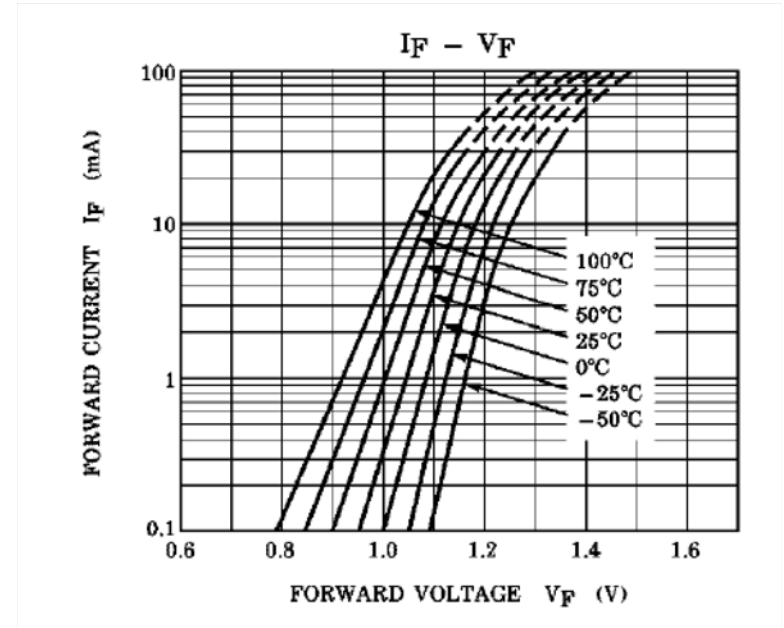

Analysis section

A current limiting resistor for the diode must be chosen.

$$R_{diode_min} := \frac{(Power_supply_total - Vf_diode_warm)}{LM239_I_sink_min} = 4.817 \cdot k\Omega$$

Choose a value greater than or equal to above:

$$R_{diode_actual} := 4.87k\Omega$$

Actual current is:

$$R_{diode_current} := \frac{(Power_supply_total - Vf_diode_warm)}{R_{diode_actual}} = 5.934 \cdot mA$$

With the resistor chosen, the output collector current can be determined:

Characteristic	Symbol	V _{DD} Vdc	- 55°C		25°C			125°C		Unit
			Min	Max	Min	Typ ⁽²⁾	Max	Min	Max	
Threshold Voltage Positive-Going	V _{T+}	5.0	2.2	3.6	2.2	2.9	3.6	2.2	3.6	Vdc
		10	4.6	7.1	4.6	5.9	7.1	4.6	7.1	
		15	6.8	10.8	6.8	8.8	10.8	6.8	10.8	
Negative-Going	V _{T-}	5.0	0.9	2.8	0.9	1.9	2.8	0.9	2.8	Vdc
		10	2.5	5.2	2.5	3.9	5.2	2.5	5.2	
		15	4.0	7.4	4.0	5.8	7.4	4.0	7.4	

Schmitt Trigger Specs

$$\text{Output_collector_current} := \left[\frac{(\text{Power_supply_total} - V_f\text{_diode_warm} - \text{LM239_VCE_sat})}{R_{\text{diode_actual}}} \right] \cdot \text{CTR_min}$$

$$\text{Output_collector_current} = 2.926 \cdot \text{mA}$$

Now the minimum value pullup resistor on the open collector output can be determined to ensure a logic low is reached.

$$R_{\text{collector_min}} := \frac{\text{Logic_supply}}{\text{Output_collector_current}}$$

$$R_{\text{collector_min}} = 1.709 \cdot \text{k}\Omega$$

Also the maximum resistor on the open collector output can be determined by using the maximum dark current.

$$R_{\text{collector_max}} := \frac{\text{Logic_supply} - \text{Schmitt_logic_low_min}}{\text{Dark_current}} = 4.1 \times 10^5 \cdot \text{k}\Omega$$

Now a resistor can be chosen. There is a wide range that will work. A relatively large value will be better due to the RC filter that will be created below.

$$R_{\text{collector_actual}} := 100 \text{ k}\Omega$$

The final max collector current will be:

$$I_{\text{collector}} := \frac{\text{Logic_supply}}{R_{\text{collector_actual}}} = 0.05 \cdot \text{mA}$$

For the RC filter, a divider will be formed. This divider must output a voltage lower than the minimum logic low level. Using the resistor and supply voltage, the RC divider resistor must be less than:

Guess

$$R_{\text{C_divider}} := 1 \text{ k}\Omega$$

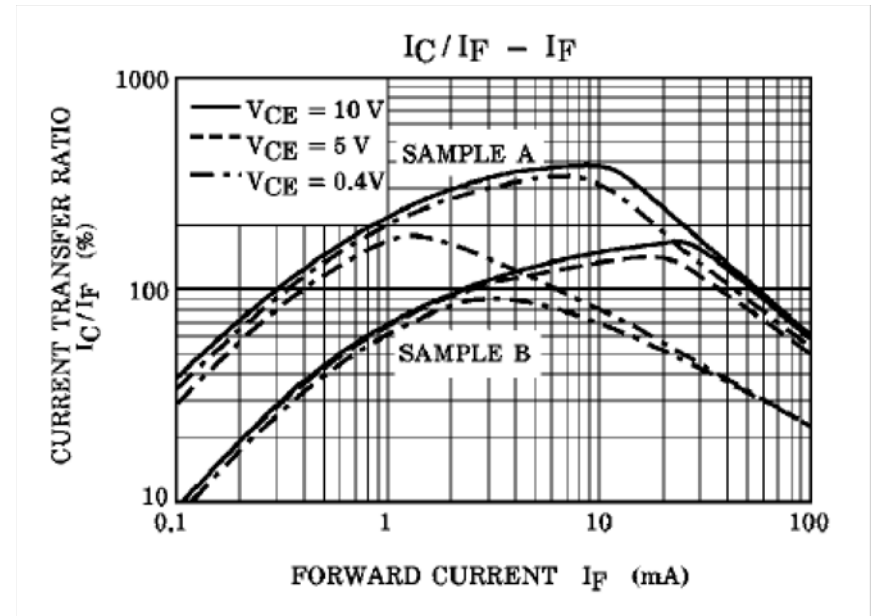

CHARACTERISTIC	SYMBOL	TEST CONDITION	MIN.	TYP.	MAX.	UNIT
Current Transfer Ratio	I_C / I_F	$I_F = 5 \text{ mA}, V_{CE} = 5 \text{ V}$	50	—	600	%
		Rank GB	100	—	600	
Saturated CTR	$I_C / I_F (\text{sat})$	$I_F = 1 \text{ mA}, V_{CE} = 0.4 \text{ V}$	—	60	—	%
		Rank GB	30	—	—	
Collector-Emitter Saturation Voltage	$V_{CE} (\text{sat})$	$I_C = 2.4 \text{ mA}, I_F = 8 \text{ mA}$	—	—	0.4	V
		$I_C = 0.2 \text{ mA}, I_F = 1 \text{ mA}$	—	0.2	—	
Off-State Collector Current	$I_C (\text{off})$	$V_F = 0.7 \text{ V}, V_{CE} = 48 \text{ V}$	—	—	10	μA

Given

$$\text{opto_VCE_sat_max} + \frac{\text{RC_divider}}{\text{RC_divider} + \text{R_collector_actual}} \cdot (\text{Logic_supply} - \text{opto_VCE_sat_max}) = \text{Schmitt_logic_low_min}$$

$$\text{Find}(\text{RC_divider}) = 12.195 \cdot \text{k}\Omega$$

Select a value less than the above:

$$\text{R_divider_actual} := 6.81 \text{ k}\Omega$$

Actual low logic level, worst case:

$$\text{Logic_low_input} := \text{opto_VCE_sat_max} + \left(\frac{\text{R_divider_actual}}{\text{R_divider_actual} + \text{R_collector_actual}} \right) (\text{Logic_supply} - \text{opto_VCE_sat_max})$$

$$\text{Logic_low_input} = 0.693 \text{ V}$$

The two resistors form a Thevenin resistance with a Thevenin voltage equal to the divider voltage. The circuit discharges the capacitor from 5V. The approximate capacitor required for the low pass, using worst case logic level low input values, is:

$$\text{R_div_thevenin} := \frac{\text{R_divider_actual} \cdot \text{R_collector_actual}}{\text{R_divider_actual} + \text{R_collector_actual}} = 6.376 \cdot \text{k}\Omega$$

Using the worst case situation where a sign wave is completely squared after the optocoupler (50% duty cycle square wave):

$$\text{pulse_width_reject} := \frac{1}{2 \cdot \text{LP_freq_cutoff}} = 5 \cdot \text{ms}$$

With the pulse width to filter and the worst case (max) logic low input signal to the Schmitt trigger:

guess

$$\text{div_cap} := 0.33 \mu\text{F}$$

Given

$$\left(\frac{\text{R_divider_actual}}{\text{R_divider_actual} + \text{R_collector_actual}} \right) \cdot \text{Logic_supply} + \left[\text{Logic_supply} \cdot \left[1 - \left(\frac{\text{R_divider_actual}}{\text{R_divider_actual} + \text{R_collector_actual}} \right) \right] \right] \cdot e^{\left(\frac{-\text{pulse_width_reject}}{\text{R_div_thevenin} \cdot \text{div_cap}} \right)} = \text{Schmitt_logic_low_max}$$

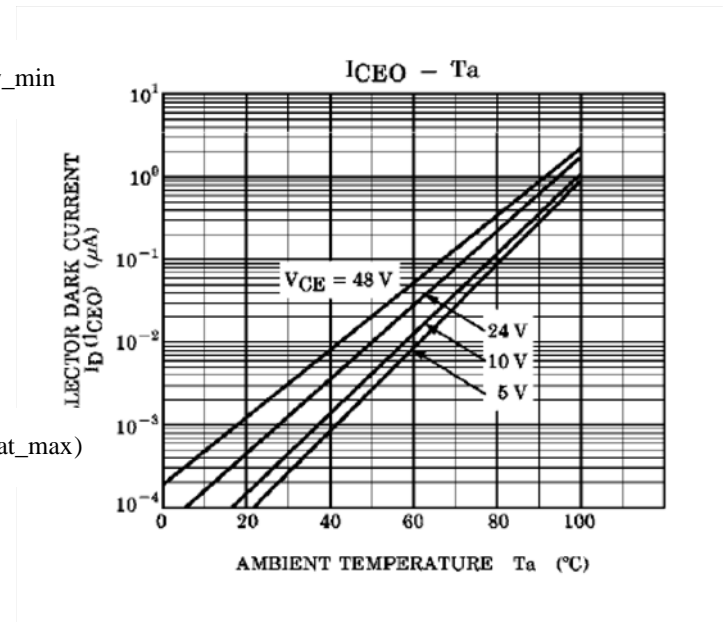

$$\text{Find}(\text{div_cap}) = 1.235 \cdot \mu\text{F}$$

Select the actual filter capacitor:

$$\text{schmitt_cap} := 1 \mu\text{F}$$

The optocoupler and Schmitt trigger circuit will filter out pulse less than or equal to:

guess

$$\text{pulse_filter_actual} := 10\text{ms}$$

Given

$$\left(\frac{R_{\text{divider_actual}}}{R_{\text{divider_actual}} + R_{\text{collector_actual}}} \right) \cdot \text{Logic_supply} + \left[\text{Logic_supply} \cdot \left[1 - \left(\frac{R_{\text{divider_actual}}}{R_{\text{divider_actual}} + R_{\text{collector_actual}}} \right) \right] \right] \cdot e^{\left(\frac{-\text{pulse_filter_actual}}{R_{\text{div_thevenin}} \cdot \text{schmitt_cap}} \right)} = \text{Schmitt_logic_low_max}$$

$$\text{filtered_pulse_width} := \text{Find}(\text{pulse_filter_actual})$$

$$\text{filtered_pulse_width} = 4.047 \cdot \text{ms}$$

$$\text{filtered_frequency_cutoff_min} := \frac{1}{2 \cdot \text{filtered_pulse_width}} = 123.535 \cdot \text{Hz}$$

Comparator Circuits & Signal Conditioning Amps

BACKGROUND: comparators are used for overcurrent and overspeed sensing. An op-amp stage provides signal conditioning. The axis motors have a 1Ω winding resistance and there is a 1Ω resistor in series from the amplifier. +90V is the supply for the amplifiers. Therefore, 90/2=45A is the maximum current possible. The NC307 amplifiers used for both the axis motors and the dome motors have a 35A continuous and 105A peak output rating.

Directions

Fill in yellow highlighted regions.

Pink highlighted areas are results of interest.

Variables

input_filter_cutoff := 20Hz **Input stage filtering approximate goal.**

comp_hysteresis_goal := 100mV **Hysteresis goal as a percentage of the reference.**

Vsupply_comp_neg := -15V **Total supply voltage, rail to rail.**

Vsupply_comp_pos := 15V **Total supply voltage, rail to rail.**

LM339_I_sink_min := 6mA **Min sink current.**

LM339_VCE := 0.4V **LM339 VCE sat.**

Overspeed_limit := 2000 $\frac{\text{arcsec}}{\text{s}}$ **Overspeed limit. Rather precise.**

Dome_amp_limit := 49.13A **Not a precise value, 40A+ is target. Value chosen for convenient resistor. It's intended for catastrophic events.**

Motor_amp_limit := 35.6A **Not a precise value, ~35A is target. Value chosen for convenient resistor. It's intended for catastrophic events.**

Analysis section

First the voltages limits of the various signals must be examined coming onto the board. The NC307 has 35A continuous and 105A peak.

$$V_{\text{dome_amp_limit}} := \left(\frac{1}{11.66 \frac{\text{A}}{\text{V}}} \right) \cdot \text{Dome_amp_limit} = 4.214 \text{ V}$$

$$V_{\text{motor_amp_limit}} := \left(\frac{1}{11.66 \frac{\text{A}}{\text{V}}} \right) \cdot \text{Motor_amp_limit} = 3.053 \text{ V}$$

$$V_{\text{overspeed}} := \left(1.7 \frac{\text{mV}}{\frac{\text{arcsec}}{\text{s}}} \right) \cdot \text{Overspeed_limit} = 3.4 \text{ V}$$

The current output driver on the NC307 has 2.7k Ω of source resistance. So any conditioning stage should have relatively high resistance. The supplies for the comparators are +/- 15V. So a wide range of reference voltages could be selected and the gain adjusted accordingly. These signals are bipolar, so an equal negative reference will also be required.

To take advantage of the maximum resolution, a reference greater than the largest input limit could be selected:

$$\max(V_{\text{dome_amp_limit}}, V_{\text{motor_amp_limit}}, V_{\text{overspeed}}) = 4.214 \text{ V}$$

Select a reference.

$$\text{comp_reference} := 5\text{V}$$

Lets determine the nominal gain resistors for the op-amps. We'll use a non-inverting op-amp, which has a gain of 1 or higher and high impedance.

Select a convenient feedback resistor:

$$R_{\text{feedback}} := 10\text{k}\Omega$$

The nominal gain resistors for each type of limit will be:

$$Rs_dome_limit := \frac{R_feedback}{\frac{comp_reference + comp_hysterisis_goal}{V_dome_amp_limit} - 1} = 47.533 \cdot k\Omega$$

$$Rs_motor_limit := \frac{R_feedback}{\frac{comp_reference + comp_hysterisis_goal}{V_motor_amp_limit} - 1} = 14.917 \cdot k\Omega$$

$$Rs_overspeed := \frac{R_feedback}{\frac{comp_reference + comp_hysterisis_goal}{V_overspeed} - 1} = 20 \cdot k\Omega$$

Select resistors for the above calculations:

$$Rs_dome_actual := 47.5k\Omega$$

$$Dome_gain_error := \frac{\left(1 + \frac{Rs_dome_actual}{R_feedback}\right)}{\left(1 + \frac{Rs_dome_limit}{R_feedback}\right)} - 1 = -0.057\%$$

$$Rs_motor_actaul := 15k\Omega$$

$$Motor_gain_error := \frac{\left(1 + \frac{Rs_motor_actaul}{R_feedback}\right)}{\left(1 + \frac{Rs_motor_limit}{R_feedback}\right)} - 1 = 0.335\%$$

$$Rs_overspeed_actual := 20k\Omega$$

$$Overspeed_gain_error := \frac{\left(1 + \frac{Rs_overspeed_actual}{R_feedback}\right)}{\left(1 + \frac{Rs_overspeed}{R_feedback}\right)} - 1 = 0\%$$

The filter is a simple, single pole, RC on the "+" terminal. Choose the capacitor first.

$$C_{\text{cond_amp}} := 1\mu\text{F}$$

The required resistor for the specified frequency is:

$$R_{\text{cond_calc}} := \frac{1}{2 \cdot \pi \cdot C_{\text{cond_amp}} \cdot \text{input_filter_cutoff}} = 7.958 \cdot \text{k}\Omega$$

Select the final resistor. This is just an approximate filter, so choose a convenient value.

$$R_{\text{cond_actual}} := 10\text{k}\Omega$$

Final filter -3dB frequency is:

$$\text{input_filter_freq} := \frac{1}{2 \cdot \pi \cdot C_{\text{cond_amp}} \cdot R_{\text{cond_actual}}} = 15.915 \cdot \text{Hz}$$

A fair amount of hysteresis is desirable in the comparator stage. Three resistors are required - pullup, feedback, and source. For each comparator, the hysteresis in one direction only is important. For example, on the positive comparator, only the positive going trip point is important. The negative going can have a relatively wide range as long as it has a "reasonable" value so the comparator can change states.

The pullup resistor should be a lower value and is limited by the sink current of the comparator.

$$R_{\text{pullup_min}} := \frac{(V_{\text{supply_comp_pos}} - V_{\text{supply_comp_neg}}) - \text{LM339_VCE}}{\text{LM339_I_sink_min}} = 4.933 \cdot \text{k}\Omega$$

Select a convenient value larger than that calculated above:

$$R_{\text{pullup_actual}} := 10\text{k}\Omega$$

Select a feedback resistor. Its value will need to be somewhat high to prevent loading on the pullup due to the input.

$$R_{\text{feedback_actual}} := 100\text{k}\Omega$$

The comparator input voltage is the reference voltage plus the hysteresis desired:

$$V_{\text{in}} := \text{comp_reference} + \text{comp_hysteresis_goal} = 5.1 \text{ V}$$

The two source resistors (dividers) for both comparators need to be determined. Setting up all of the equations and solving:

Guess

R_source_neg_trip := 2.8kΩ

R_source_pos_trip := 3kΩ

Given

$$\frac{V_{\text{supply_comp_pos}} - \left[\frac{(-\text{comp_reference} + V_{\text{in}})}{\left(\frac{R_{\text{source_neg_trip}}}{R_{\text{source_neg_trip}} + R_{\text{feedback_actual}}} \right)} - V_{\text{in}} \right]}{R_{\text{pullup_actual}}} = \frac{\frac{(-\text{comp_reference} + V_{\text{in}})}{\left(\frac{R_{\text{source_neg_trip}}}{R_{\text{source_neg_trip}} + R_{\text{feedback_actual}}} \right)} - V_{\text{in}} - \text{comp_reference}}{R_{\text{feedback_actual}} + R_{\text{source_pos_trip}}} = \frac{\frac{(-\text{comp_reference} + V_{\text{in}})}{\left(\frac{R_{\text{source_neg_trip}}}{R_{\text{source_neg_trip}} + R_{\text{feedback_actual}}} \right)}}{R_{\text{feedback_actual}} + R_{\text{source_pos_trip}}}$$

$$\frac{V_{\text{supply_comp_pos}} - \left[\frac{(V_{\text{in}} - \text{comp_reference})}{\left(\frac{R_{\text{source_pos_trip}}}{R_{\text{source_pos_trip}} + R_{\text{feedback_actual}}} \right)} + \text{comp_reference} \right]}{R_{\text{pullup_actual}}} = \frac{\frac{(V_{\text{in}} - \text{comp_reference})}{\left(\frac{R_{\text{source_pos_trip}}}{R_{\text{source_pos_trip}} + R_{\text{feedback_actual}}} \right)} + \text{comp_reference} - \text{comp_reference}}{R_{\text{feedback_actual}} + R_{\text{source_pos_trip}}} = \frac{\frac{(V_{\text{in}} - \text{comp_reference})}{\left(\frac{R_{\text{source_pos_trip}}}{R_{\text{source_pos_trip}} + R_{\text{feedback_actual}}} \right)}}{R_{\text{feedback_actual}} + R_{\text{source_pos_trip}}}$$

$$\text{Find}(R_{\text{source_pos_trip}}, R_{\text{source_neg_trip}}) = \begin{pmatrix} 1.212 \\ 0.571 \end{pmatrix} \cdot \text{k}\Omega$$

Select the final values for the two divider resistors:

$$R_{\text{source_pos_actual}} := 1.21\text{k}\Omega$$

$$R_{\text{source_neg_actual}} := 1.21\text{k}\Omega$$

The trip points on the negative threshold comparator are:

$$V_{\text{comp_out}} := 12\text{V}$$

Given

$$\frac{V_{\text{supply_comp_pos}} - V_{\text{comp_out}}}{R_{\text{pullup_actual}}} - \frac{V_{\text{comp_out}} - \text{comp_reference}}{R_{\text{feedback_actual}} + R_{\text{source_pos_actual}}} - \frac{V_{\text{comp_out}} - -V_{\text{in}}}{R_{\text{feedback_actual}} + R_{\text{source_neg_actual}}} = 0$$

$$V_{neg_comp_out_hi} := \text{Find}(V_{comp_out}) = 12.517 \text{ V}$$

$$\text{Neg_comp_neg_going} := V_{neg_comp_out_hi} - \left(\frac{V_{supply_comp_pos} - V_{neg_comp_out_hi}}{R_{pullup_actual}} - \frac{V_{neg_comp_out_hi} - \text{comp_reference}}{R_{feedback_actual} + R_{source_pos_actual}} \right) (R_{feedback_actual} + R_{source_neg_actual})$$

$$\text{Neg_comp_neg_going} = -5.1 \text{ V}$$

$$\text{Neg_comp_pos_going} := -\text{comp_reference} - R_{source_neg_actual} \cdot \frac{(V_{supply_comp_neg} - -\text{comp_reference})}{R_{feedback_actual}}$$

$$\text{Neg_comp_pos_going} = -4.879 \text{ V} \quad \text{Not really that important on exact value.}$$

The trip points on the positive threshold comparator are:

Given

$$\frac{V_{supply_comp_pos} - V_{comp_out}}{R_{pullup_actual}} - \frac{V_{comp_out} - \text{comp_reference}}{R_{feedback_actual} + R_{source_pos_actual}} - \frac{V_{comp_out} - V_{in}}{R_{feedback_actual} + R_{source_neg_actual}} = 0$$

$$V_{pos_comp_out_hi} := \text{Find}(V_{comp_out}) = 13.358 \text{ V}$$

$$\text{Pos_comp_pos_going} := V_{pos_comp_out_hi} - \left(\frac{V_{supply_comp_pos} - V_{pos_comp_out_hi}}{R_{pullup_actual}} - \frac{V_{pos_comp_out_hi} - V_{in}}{R_{feedback_actual} + R_{source_neg_actual}} \right) (R_{feedback_actual})$$

$$\text{Pos_comp_pos_going} = 5.1 \text{ V}$$

$$\text{Pos_comp_neg_going} := V_{supply_comp_neg} - R_{feedback_actual} \cdot \frac{(V_{supply_comp_neg} - \text{comp_reference})}{R_{feedback_actual} + R_{source_pos_actual}}$$

$$\text{Pos_comp_neg_going} = 4.761 \text{ V}$$

Power Filtering

BACKGROUND: some type of power filtering should be used. A damped LC filter would offer decent attenuation with low losses.

Directions

Fill in yellow highlighted regions.

Pink highlighted areas are results of interest.

Variables

PS_15V_pos := 15V	15V supply voltage.
PS_15V_pos_current := 20mA	15V supply voltage max current output.
PS_15V_neg := -15V	-15V supply voltage.
PS_15V_neg_current := 20mA	-15V supply voltage max current output.
PS_5V_SBD := 5V	5V Safety Board supply voltage.
PS_5V_SBD := 200mA	5V Safety Board supply voltage max current.
PS_5V_SE := 5V	5V FIO-SE supply voltage.
PS_5V_SE := 100mA	5V FIO-SE supply voltage max current.
filter_freq := 400Hz	Filter -3dB frequency.

Analysis section

The +/- 15V filters can be calculated first. Component sizes will limit practical filter cutoff frequency.

Choose a low ESR capacitor for the primary filter capacitor.

C_main_filter := 22μF

Which makes the dampening capacitor:

C_dampening := 4 · C_main_filter = 88 · μF

Select a value for the capacitor:

C_dampening_actual := 100μF

Depending on capacitor type, it may have significant ESR, which is actually desirable. Enter the ESR value.

C_damp_ESR := 0

The inductor may now be selected:

L_filter_actual := 5.6mH

$$\text{filter_freq_actual} := \frac{1}{2 \cdot \pi \cdot \sqrt{L_filter_actual \cdot C_main_filter}} = 453.435 \cdot \text{Hz}$$

Finally the damping resistor can be determined:

$$R_{\text{damp_res}} := \sqrt{\frac{L_{\text{filter_actual}}}{C_{\text{main_filter}}}} - C_{\text{damp_ESR}} = 15.954 \Omega$$

Select a damping R:

$$R_{\text{damp_res_act}} := 15.8 \Omega$$

Derive the filter function:

$$V_{\text{out}}(\omega) = \left[\frac{\left[\frac{1}{j\omega \cdot C_{\text{main_filter}}} \left(\frac{1}{j\omega \cdot C_{\text{dampening_actual}}} + R_{\text{damp_res_act}} \right) \right]}{\frac{1}{j\omega \cdot C_{\text{main_filter}}} + \left(\frac{1}{j\omega \cdot C_{\text{dampening_actual}}} + R_{\text{damp_res_act}} \right)} + j\omega L_{\text{filter_actual}} \right] \cdot V_{\text{in}}(\omega)$$

$$H_{\text{filter}}(\omega) := \left[\frac{\left[\frac{1}{j\omega \cdot C_{\text{main_filter}}} \left(\frac{1}{j\omega \cdot C_{\text{dampening_actual}}} + R_{\text{damp_res_act}} \right) \right]}{\frac{1}{j\omega \cdot C_{\text{main_filter}}} + \left(\frac{1}{j\omega \cdot C_{\text{dampening_actual}}} + R_{\text{damp_res_act}} \right)} + j\omega L_{\text{filter_actual}} \right]$$

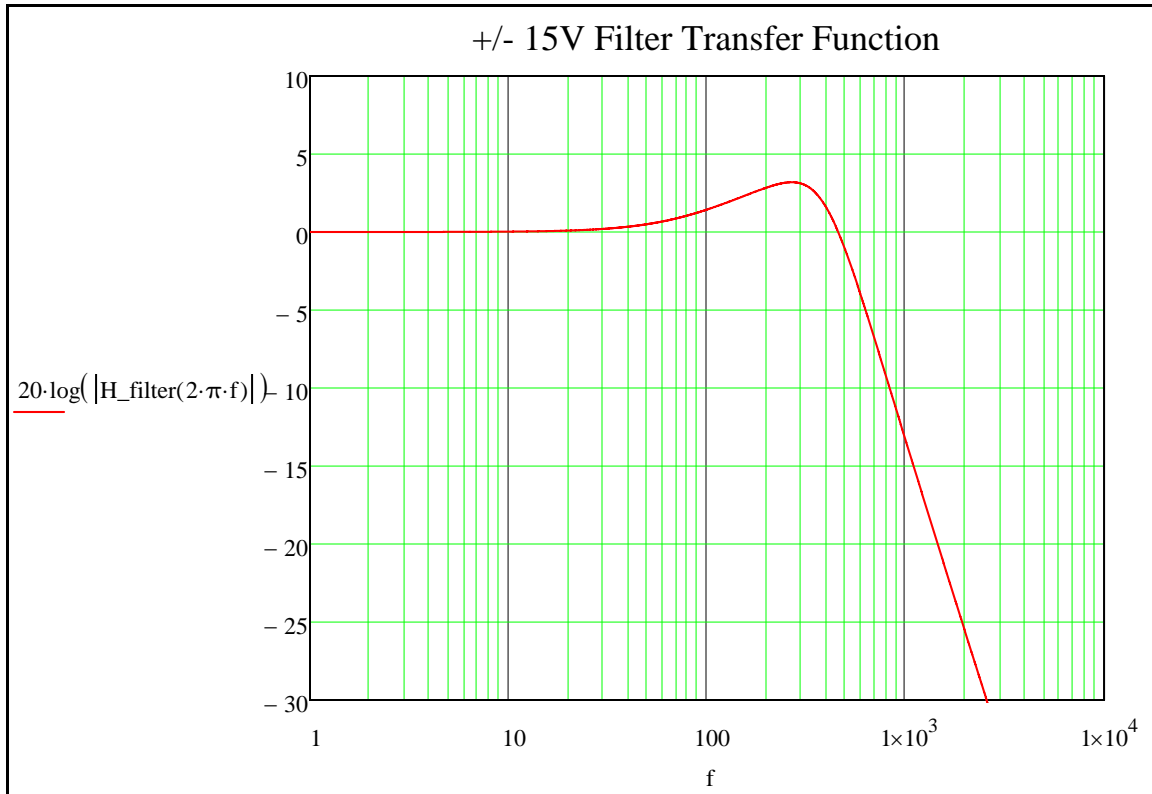

The +5V filters can be calculated next.

Choose a low ESR capacitor for the primary filter capacitor.

$C_{\text{main_filter_5V}} := 100 \mu\text{F}$

Which makes the dampening capacitor:

$C_{\text{dampening_5V}} := 4 \cdot C_{\text{main_filter_5V}} = 400 \mu\text{F}$

Select a value for the capacitor:

$C_{\text{dampening_actual_5V}} := 470 \mu\text{F}$

Depending on capacitor type, it may have significant ESR, which is actually desirable. Enter the ESR value.

$C_{\text{damp_ESR_5V}} := 0$

The inductor may now be selected:

$L_{\text{filter_actual_5V}} := 1.2 \text{mH}$ 8532 – 38ltr

$$\text{filter_freq_actual_5V} := \frac{1}{2 \cdot \pi \cdot \sqrt{L_{\text{filter_actual_5V}} \cdot C_{\text{main_filter_5V}}}} = 459.441 \cdot \text{Hz}$$

Finally the dampening resistor can be determined:

$$R_{\text{damp_res_5V}} := \sqrt{\frac{L_{\text{filter_actual_5V}}}{C_{\text{main_filter_5V}}}} - C_{\text{damp_ESR_5V}} = 3.464 \Omega$$

Select a dampening R:

$$R_{\text{damp_res_5V_act}} := 3.01 \Omega$$

$$H_{\text{filter_5V}}(\omega) := \left[\frac{\left[\frac{1}{j\omega \cdot C_{\text{main_filter_5V}}} \left(\frac{1}{j\omega \cdot C_{\text{dampening_actual_5V}}} + R_{\text{damp_res_5V_act}} \right) \right]}{\frac{1}{j\omega \cdot C_{\text{main_filter_5V}}} + \left(\frac{1}{j\omega \cdot C_{\text{dampening_actual_5V}}} + R_{\text{damp_res_5V_act}} \right)} \right] + j \cdot \omega L_{\text{filter_actual_5V}}$$

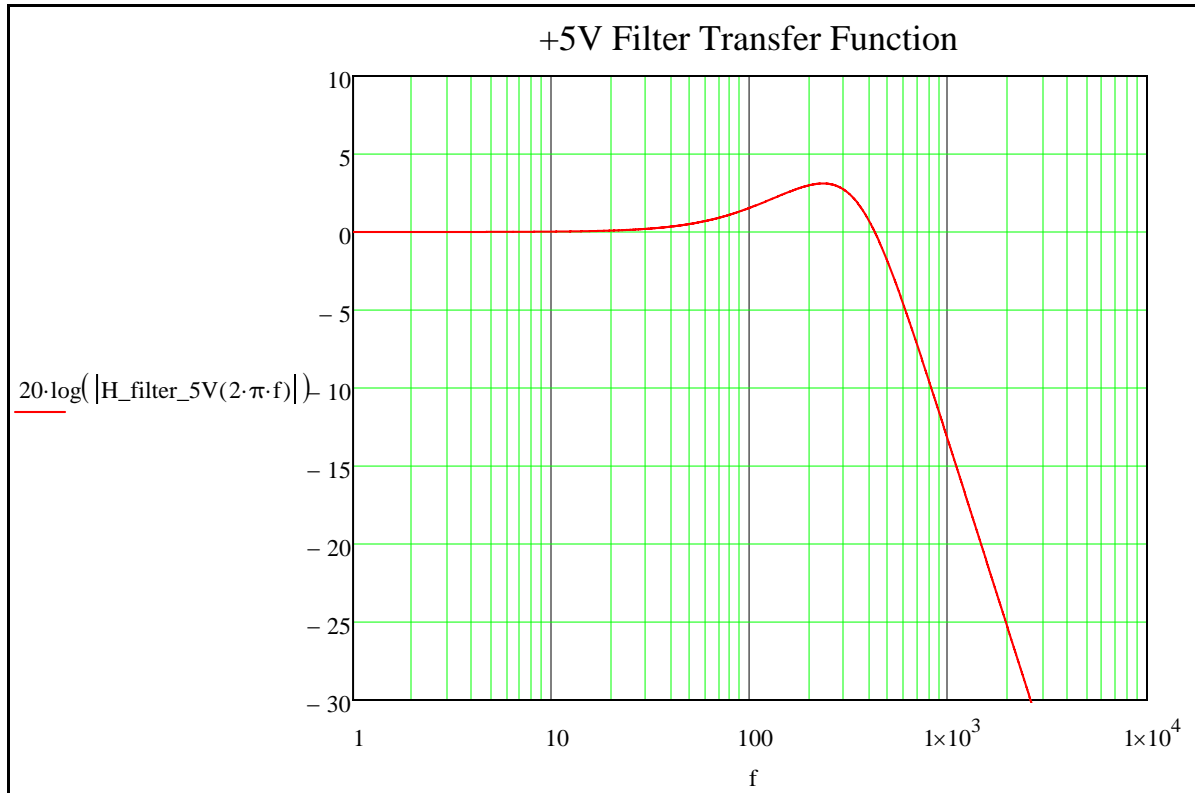

Optocoupler Circuit Driven by Limit Switches

BACKGROUND: limit switches are used on the telescope. They are simple switches and will be isolated from

board logic via optocouplers.

Directions

Fill in yellow highlighted regions.

Pink highlighted areas are results of interest.

Variables

- Logic_supply_V := 5V **Power supply voltage (Logic & switch are +5V).**
- Vf_opto_diode_cold := 1.15V **Forward diode drop at 0C, IF=5mA.**
- Vf_opto_diode_warm := 1.1V **Forward diode drop at 0C, IF=5mA.**
- opto_CTR_min := 50% **CTR min at 5mA.**
- opto_Dark_current := 0.01µA **Dark current at 60C.**
- Schmitt_logic_hi_max := 3.6V **Schmitt trigger logic high input voltage and VCE=5V.**
- Schmitt_logic_lo_max := 2.8V **Schmitt trigger logic low input voltage max.**
- Schmitt_logic_lo_min := 0.9V **Schmitt trigger logic low input voltage min.**
- optocoupler_VCE_sat_max := 0.4V **Collector-Emitter saturation voltage.**

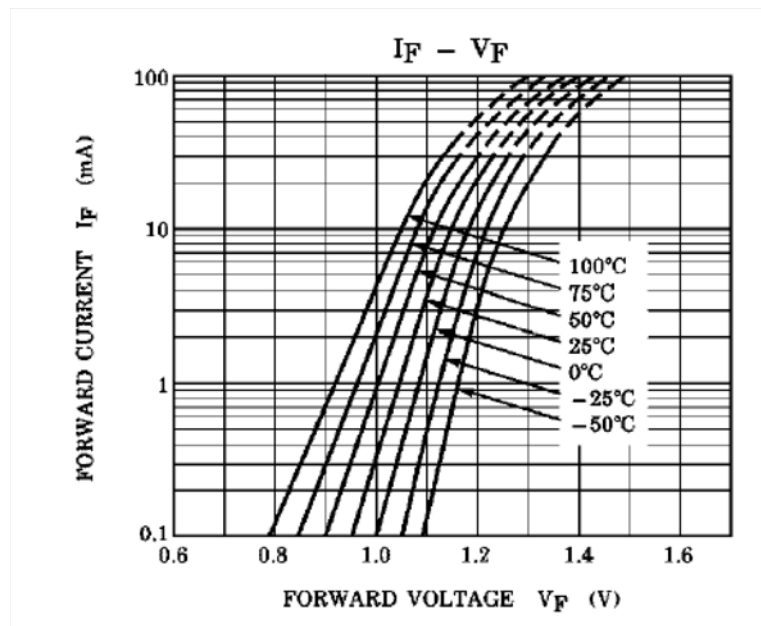

Analysis section

Since a limit switch is sinking the current, the current can be relatively large. So a reasonable value must be chosen.

switch_sink_current := 5mA

A current limiting resistor for the diode must be chosen.

$$R_diode_limit_min := \frac{(Logic_supply_V - Vf_opto_diode_warm)}{switch_sink_current} = 780 \cdot \Omega$$

Choose a value greater than or equal to above:

R_diode_limit_actual := 780Ω

Actual current is:

$$i_diode_actual := \frac{(Logic_supply_V - Vf_opto_diode_warm)}{R_diode_limit_actual} = 5 \cdot mA$$

Characteristic	Symbol	V _{DD} V _{dC}	- 55°C		25°C			125°C		Unit
			Min	Max	Min	Typ ⁽²⁾	Max	Min	Max	
Threshold Voltage Positive-Going	V _{T+}	5.0	2.2	3.6	2.2	2.9	3.6	2.2	3.6	V _{dC}
		10	4.6	7.1	4.6	5.9	7.1	4.6	7.1	
		15	6.8	10.8	6.8	8.8	10.8	6.8	10.8	
Negative-Going	V _{T-}	5.0	0.9	2.8	0.9	1.9	2.8	0.9	2.8	V _{dC}
		10	2.5	5.2	2.5	3.9	5.2	2.5	5.2	
		15	4.0	7.4	4.0	5.8	7.4	4.0	7.4	

Schmitt Trigger Specs

With the resistor chosen, the output collector current can be determined:

$$\text{Opto_collector_current} := \left[\frac{(\text{Logic_supply_V} - V_{f_opto_diode_warm})}{R_{diode_limit_actual}} \right] \cdot \text{CTR_min}$$

$$\text{Opto_collector_current} = 2.5 \cdot \text{mA}$$

Now the minimum value pullup resistor on the open collector output can be determined to ensure a logic low is reached.

$$R_{pullup_collector_min} := \frac{\text{Logic_supply_V}}{\text{Opto_collector_current}}$$

$$R_{pullup_collector_min} = 2 \cdot \text{k}\Omega$$

Also the maximum resistor on the open collector output can be determined by using the maximum dark current.

$$R_{pullup_collector_max} := \frac{\text{Logic_supply_V} - \text{Schmitt_logic_lo_min}}{\text{opto_Dark_current}} = 4.1 \times 10^5 \cdot \text{k}\Omega$$

Now a resistor can be chosen. There is a wide range that will work. A relatively large value will be better due to the RC filter that will be created below.

$$R_{pullup_collector_actual} := 100 \text{ k}\Omega$$

The final max collector current will be:

$$I_{opto_collector} := \frac{\text{Logic_supply_V}}{R_{pullup_collector_actual}} = 0.05 \cdot \text{mA}$$

For the RC filter, a divider will be formed. This divider must output a voltage lower than the minimum logic low level. Using the resistor and supply voltage, the RC divider resistor must be less than:

Guess

$$RC_{pullup_divider} := 1 \text{ k}\Omega$$

Given

$$\text{optocoupler_VCE_sat_max} + \frac{RC_{pullup_divider}}{RC_{pullup_divider} + R_{pullup_collector_actual}} \cdot (\text{Logic_supply_V} - \text{optocoupler_VCE_sat_max}) = \text{Schmitt_logic_lo_min}$$

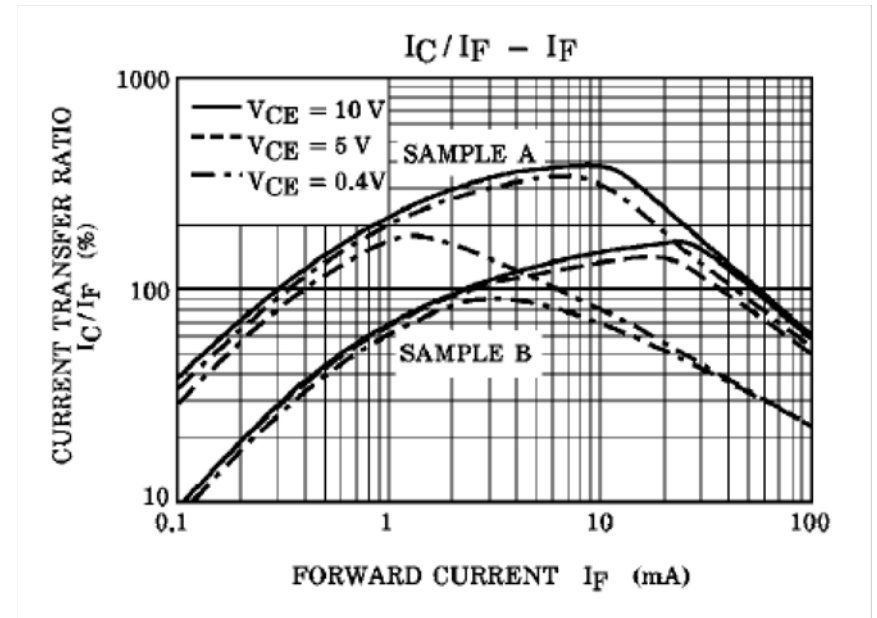

CHARACTERISTIC	SYMBOL	TEST CONDITION	MIN.	TYP.	MAX.	UNIT
Current Transfer Ratio	I_C / I_F	$I_F = 5 \text{ mA}, V_{CE} = 5 \text{ V}$	50	—	600	%
		Rank GB	100	—	600	
Saturated CTR	$I_C / I_F (\text{sat})$	$I_F = 1 \text{ mA}, V_{CE} = 0.4 \text{ V}$	—	60	—	%
		Rank GB	30	—	—	
Collector-Emitter Saturation Voltage	$V_{CE} (\text{sat})$	$I_C = 2.4 \text{ mA}, I_F = 8 \text{ mA}$	—	—	0.4	V
		$I_C = 0.2 \text{ mA}, I_F = 1 \text{ mA}$	—	0.2	—	
		Rank GB	—	—	0.4	
Off-State Collector Current	$I_C (\text{off})$	$V_F = 0.7 \text{ V}, V_{CE} = 48 \text{ V}$	—	—	10	μA

$$\text{Find}(\text{RC_pullup_divider}) = 12.195 \cdot \text{k}\Omega$$

Select a value less than the above:

$$\text{RC_pullup_divider_actual} := 6.81 \text{ k}\Omega$$

Actual low logic level, worst case:

$$\text{Logic_lo_input} := \text{optocoupler_VCE_sat_max} + \left(\frac{\text{RC_pullup_divider_actual}}{\text{RC_pullup_divider_actual} + \text{R_pullup_collector_actual}} \right) (\text{Logic_supply_V} - \text{optocoupler_VCE_sat_max})$$

$$\text{Logic_lo_input} = 0.693 \text{ V}$$

The two resistors form a Thevenin resistance with a Thevenin voltage equal to the divider voltage. The circuit discharges the capacitor from 5V. The approximate capacitor required for the low pass, using worst case logic level low input values, is:

$$\text{R_div_thevenin} := \frac{\text{R_divider_actual} \cdot \text{R_collector_actual}}{\text{R_divider_actual} + \text{R_collector_actual}} = 6.376 \cdot \text{k}\Omega$$

Using the worst case situation where a sign wave is completely squared after the optocoupler (50% duty cycle square wave):

$$\text{pulse_width_reject} := \frac{1}{2 \cdot \text{LP_freq_cutoff}} = 5 \cdot \text{ms}$$

With the pulse width to filter and the worst case (max) logic low input signal to the Schmitt trigger:

guess

$$\text{div_cap} := 0.33 \mu\text{F}$$

Given

$$\left(\frac{\text{R_divider_actual}}{\text{R_divider_actual} + \text{R_collector_actual}} \right) \cdot \text{Logic_supply} + \left[\text{Logic_supply} \cdot \left[1 - \left(\frac{\text{R_divider_actual}}{\text{R_divider_actual} + \text{R_collector_actual}} \right) \right] \right] \cdot e^{\left(\frac{-\text{pulse_width_reject}}{\text{R_div_thevenin} \cdot \text{div_cap}} \right)} = \text{Schmitt_logic_low_max}$$

$$\text{Find}(\text{div_cap}) = 1.235 \cdot \mu\text{F}$$

Select the actual filter capacitor:

$$\text{schmitt_cap} := 1 \mu\text{F}$$

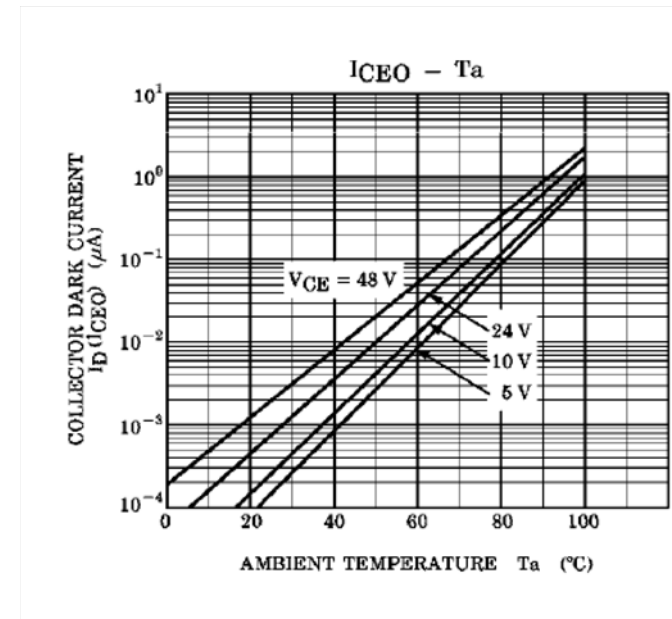

The optocoupler and Schmitt trigger circuit will filter out pulse less than or equal to:

guess

pulse_filter_actual := 10ms

Given

$$\left(\frac{R_{\text{divider_actual}}}{R_{\text{divider_actual}} + R_{\text{collector_actual}}} \right) \cdot \text{Logic_supply} + \left[\text{Logic_supply} \cdot \left[1 - \left(\frac{R_{\text{divider_actual}}}{R_{\text{divider_actual}} + R_{\text{collector_actual}}} \right) \right] \right] \cdot e^{\left(\frac{-\text{pulse_filter_actual}}{R_{\text{div_thevenin}} \cdot \text{schmitt_cap}} \right)} = \text{Schmitt_logic_low_max}$$

filtered_pulse_width := Find(pulse_filter_actual)

filtered_pulse_width = 4.047·ms

filtered_frequency_cutoff_min := $\frac{1}{2 \cdot \text{filtered_pulse_width}}$ = 123.535·Hz

Parallel Port & Optocoupler

BACKGROUND: the parallel port from the TCS3 PC connects to the safety board. It should be isolated via optocouplers. The only issue is that parallel ports are weak drivers (i.e. high source impedance). The output of the optocoupler will be identical to other optocouplers (see above for details). According to an internet search, UM82C11-C was/is a popular choice.

Directions

Fill in **yellow highlighted** regions.

Pink highlighted areas are results of interest.

Variables

parallel_port_supply := 5V **Parallel port supply voltage.**
parallel_port_V := 2.4V **Parallel port voltage at 2.6mA.**
parallel_port_i := 2.6mA **Parallel port current at 2.4V.**
parallel_port_out_num := 5 **Number of parallel port output.**
opto_Vf_diode_cold := 1.15V **Forward diode drop at 0C, IF=5mA.**
opto_Vf_diode_warm := 1.1V **Forward diode drop at 0C, IF=5mA.**
opto_CTR_ratio_min := 50% **CTR min at 5mA.**
optocoupler_Dark_current := 0.01μA **Dark current at 60C.**

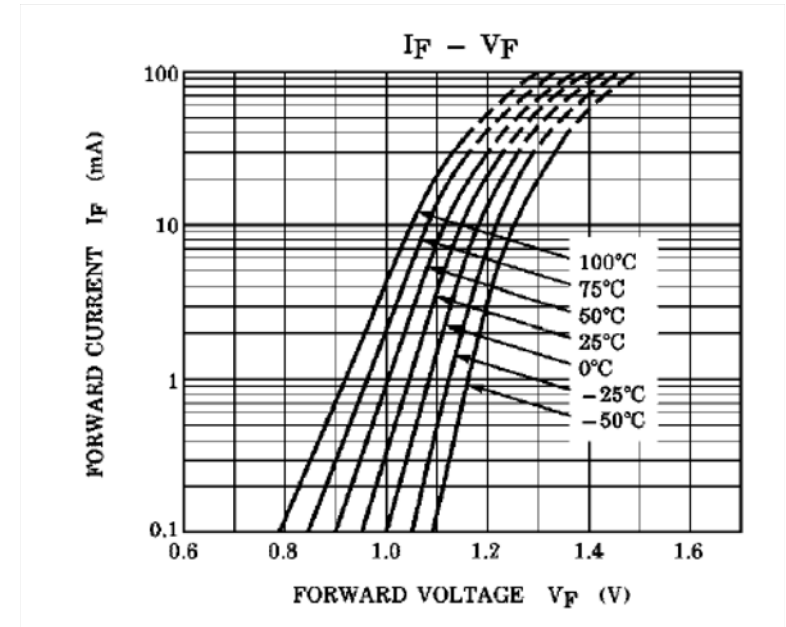

Analysis section

Since the current and voltage of the parallel port is given, the source impedance can be determined.

$$R_{\text{source}} := \frac{\text{parallel_port_supply} - \text{parallel_port_V}}{\text{parallel_port_i}} = 1 \cdot \text{k}\Omega$$

Pick a current drive value that is less than the the parallel port specified current. A value similar to that in the previous section on optocouplers for limit switches would be good. This way the same outpu components can be used.

$i_{\text{diode_actual}} = 5 \cdot \text{mA}$ **Previous section's choice for diode drive current.**

diode_drive_current := 2mA

Now the current limiting resistor can be determined:

$$R_{\text{diode_limit}} := \frac{(\text{parallel_port_supply} - \text{opto_Vf_diode_warm})}{\text{diode_drive_current}} - R_{\text{source}} = 950 \cdot \Omega$$

Choose an acutal value for the resistor:

R_diode_drive_limit_actual := 1k Ω

Final drive current, per output is:

$$\text{diode_current_final} := \frac{(\text{parallel_port_supply} - \text{opto_Vf_diode_warm})}{\text{R_diode_drive_limit_actual} + \text{R_source}} = 1.95 \cdot \text{mA}$$

The maximum current that the parallel port IC would have to drive is:

$$\text{parallel_port_output_current_max} := \text{parallel_port_out_num} \cdot \text{diode_current_final}$$

$$\text{parallel_port_output_current_max} = 9.75 \cdot \text{mA}$$